



MAUSA Machine Tools:

- **FV e FVM line - CNC Boring and Milling**
- **SMART C line - CNC Vertical lathes**

Mausa has more than seventy years of history, offering the best solutions in medium and large size machines for medium and large companies



Founded in 1948, Mausa S / A Equipamentos Industriais is today a major supplier of products for the heavy industry. The septuagenarian company employs around 400 employees and provides an extensive list of products.

We are a vertical company, we execute all the necessary processes for the manufacture of our equipment, with dedicated engineering for each business unit.

From the Mausa portfolio we can highlight the following: centrifuges, filters, dryers, vacuum pumps, cranes and gantries, boring machines, milling machines and medium and large vertical lathes.

1948 Plant



Current Plant



322,917 ft² of built area in an own area of **1,829,865 ft²** located in the Distrito Industrial Unileste- Piracicaba/SP.

MAUSA – Machine Tools



Horizontal Boring & Milling Machines



Vertical Lathes **NOT ALLOWED TO USA MARKET**



Multitasking & “Made by Taylor”

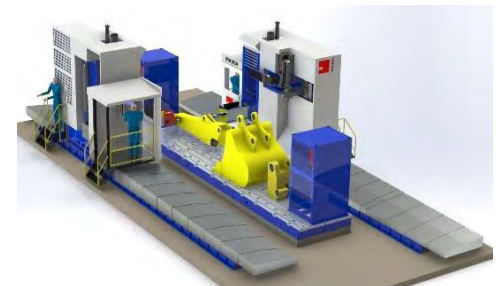
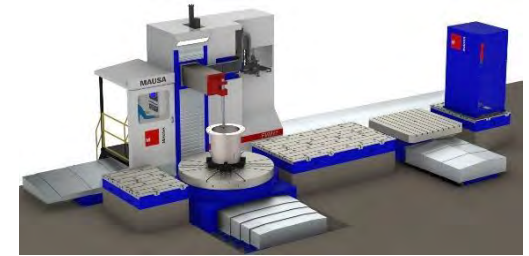

CNC Boring and Milling Line



“T-Type” Boring and Milling Machine

FV 101T Vertical stroke from 78.7 to 118.1 in.
FV 101T Subsea Vertical stroke from 78.7 to 118.1 in.
Aerospace FVM 100T Vertical stroke of 78.7 in.

“Floor Type” Boring and Milling Machines:

FVM 70/71 Vertical stroke of 63 in.
FVM 80/81 Vertical stroke from 59.1 to 98.4 in.
FVM 100/101 Vertical stroke from 98.4 mm to 118.1 in.
FV 301 Vertical stroke from 118.1 to 196.9 in.
FVM 501 Vertical stroke from 196.9 to 315 in.

Model finished in “0” => Milling e.g.: FVM 80

Model finished in “1” => Boring & Milling e.g.: FVM 81

MAUSA Technology



Thanks to technology transfer partnerships with traditional companies and engineering offices in Europe, Mause has developed its technical and manufacturing capacity to produce a wide range of CNC boring and milling machines, with the most advanced concepts and technologies on the world market.



MAUSA Technology



With the complete qualification of the manufacturing, assembly and inspection processes, Mausa provides adequate solutions with a high degree of customization for the most diverse machining applications, guaranteeing reliability, services and safety to its customers.



CNC Systems



SIEMENS

- 840D sl
- 828D



HEIDENHAIN

- TNC 640
- TNC 620



FANUC

- 31 i - MF
- 0 i - MF

Customized solutions and flexibility

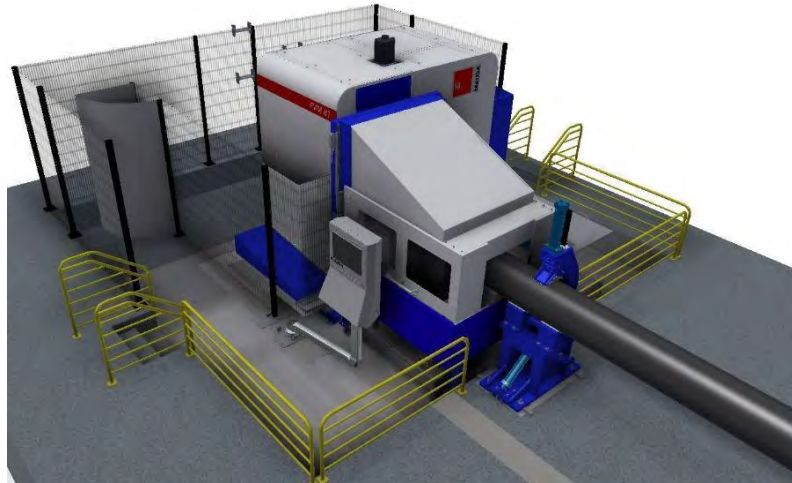

Machining Cell for MLP
(mechanically lined pipes)

Solutions and studies for specific applications

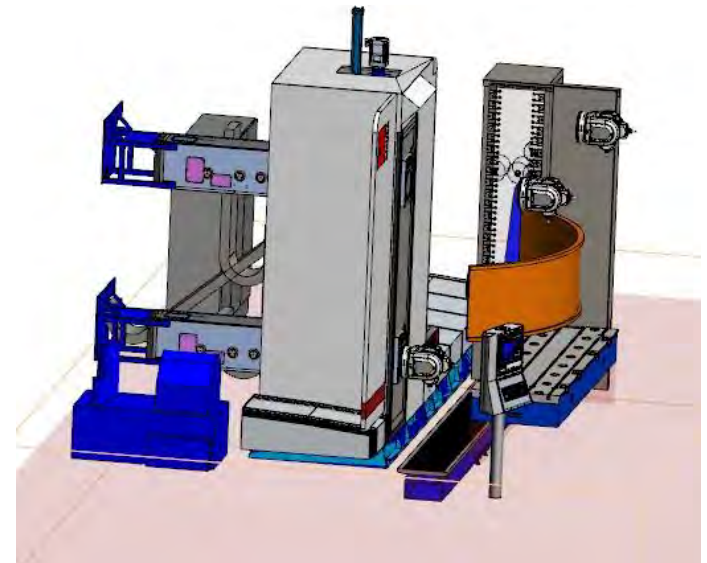
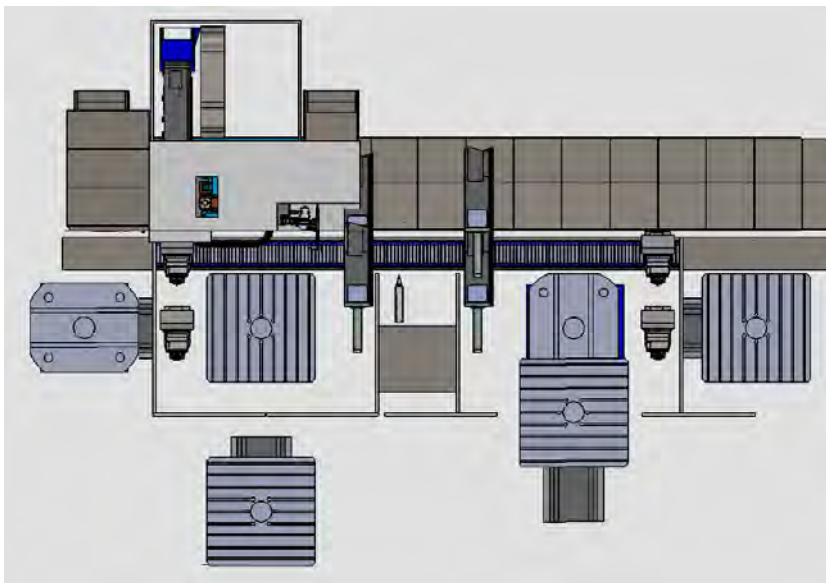
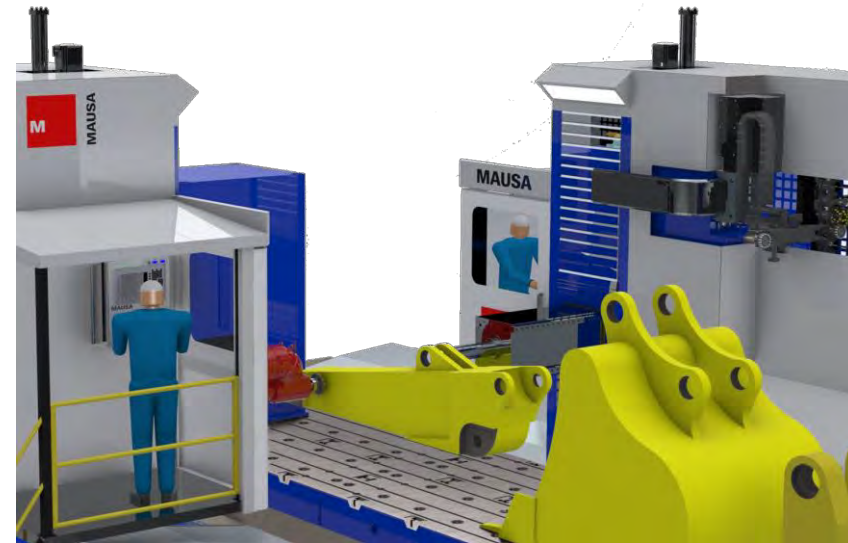
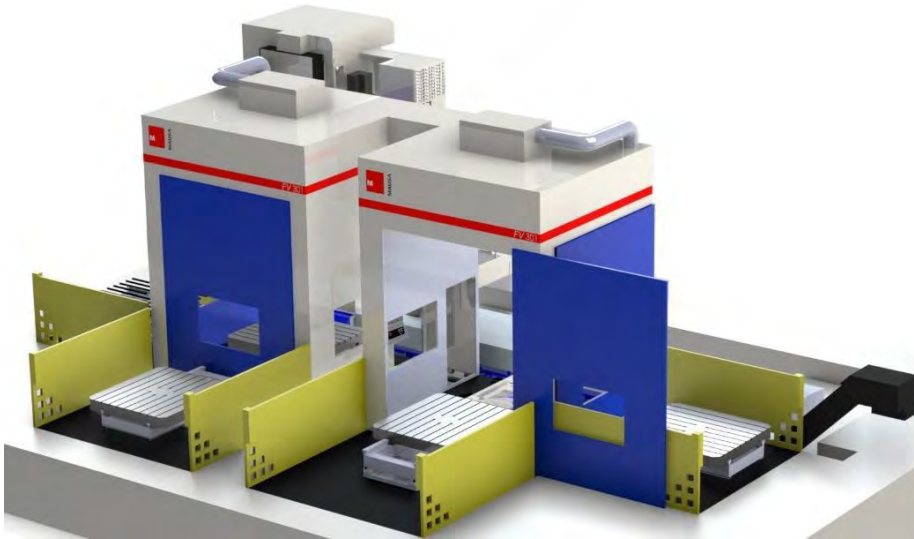



“T-Type” Machines

- **FV 101T & FV 101T Subsea**
- **FVM 100T Aerospace**

FV 101T & FV 101T Subsea “T -Type” Boring and Milling Machine



MAUSA



Technical specifications



MAUSA

		FV 101 T	FV 101 T subsea
Table longitudinal travel (X axis)	in	137.8	157.5
Headstock vertical travel (Y axis)	in	118.1	
Column transversel travel (Z axis)	in	98.4	137.8
Boring spindle axial travel (W axis)	in	27.6	35.4
Spindle diameter (quill)	in	5.1	6.3
Table surface	in	70.9 x 70.9 up to 78.7 x 118.1	
Table load capacity	lbs	33,069 or 66,139	
Minimum angular increment (B axis)	degrees	0,001°	
Spindle Power S1-100% (S6-40%)	HP	55 (81.9)	85.9 (107.4)
Spindle nose	ISO	50	
Max speed	rpm	4,000	3,000
Speed range (automatic)	unit	2	
Nominal torque S1-100%	in lbf	15,046	20,357
Rapid traverse X, Y and Z	ipm	984.3	

Technical characteristics



The CNC Boring Machine FV 101T has a robust structure and design concepts, to meet a wide range of medium and large parts applications, which require high productivity and a high degree of precision.

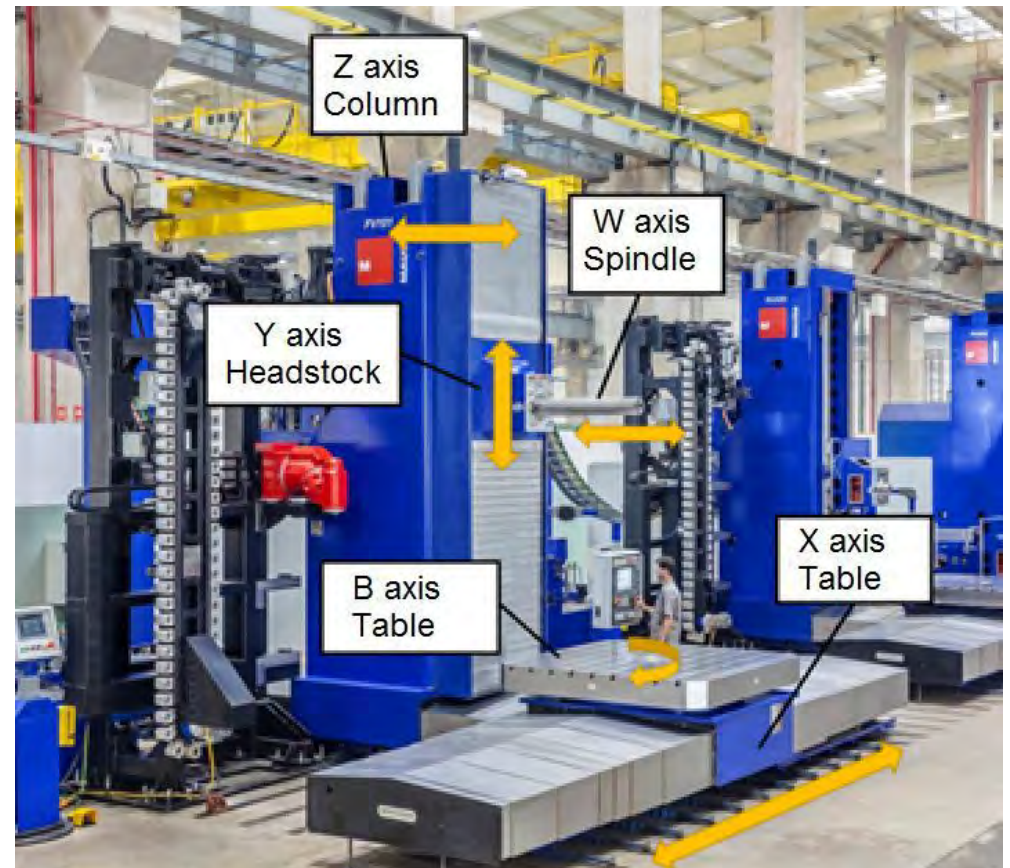

Technical characteristics



“Box in Box” concept



The headstock is positioned in the center of the double-walled column, in the “Box in Box” concept, having two front and rear guides, providing great geometric stability and high rigidity, responding uniformly to machining forces, regardless of cutting directions.

The spindle, located inside the headstock, is made of forged and tempered alloy steel and assembled with high precision ball bearings



Technical characteristics



The lubrication is achieved by means of a special system, air-oil, lubricating and cooling the entire assembly, allowing uninterrupted work at high rpm



The head carriage structure projects the spindle face 19.3" (490 mm) from the column. (reach x work area)

Technical characteristics



MAUSA

Competitors

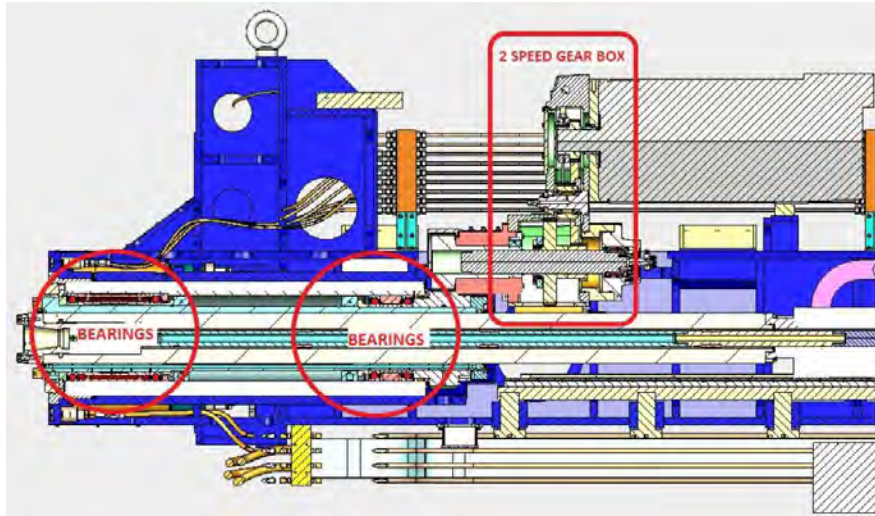

COMPETITOR OLD STYLE DESIGN 1

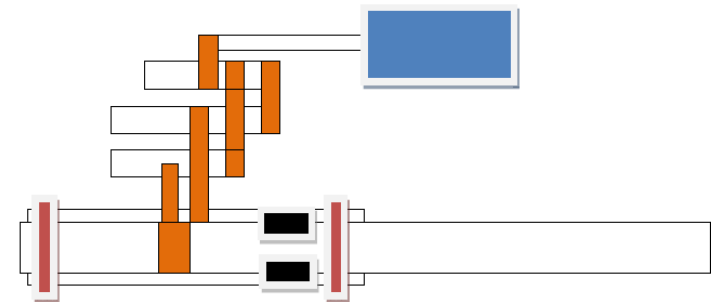

COMPETITOR STYLE DESIGN 2

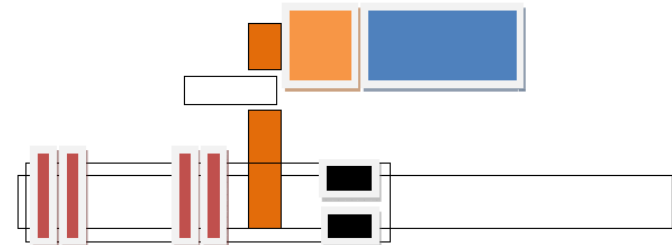

The gearbox is external and strategically positioned so that the power transmission is outside the spindle bearings. It avoids the generation of heat in the spindle and maintains the balance and constant preloads of the bearings. It has sensor for reading and overtemperature alarm and two speed ranges providing high torque at the lowest speeds

Technical characteristics



Hydrostatic Rotary Table with B axis for interpolation or angular positioning (0.001°) and linear X axis.

- Welded, structured bench and tension relief process.
- Roller linear guides, 65 mm (2.6") size.
- Heidenhain optical scale.
- Ballscrew with \varnothing 80 mm (3.15")..
- Hydraulic, lubrication, pneumatic "on board".



Technical characteristics



- All Mausa rotary tables are hydrostatic.
- The rotation of the table is done on a thin layer of pressurized and controlled oil
- The hydrostatic system eliminates the stick-slip effect.
- 36,000 pulses Heidenhain encoder, directly coupled to a table
- Hydraulic brakes
- Reduction box with double preload pinion (eliminate backlash).
- Crown with ground helical teeth.

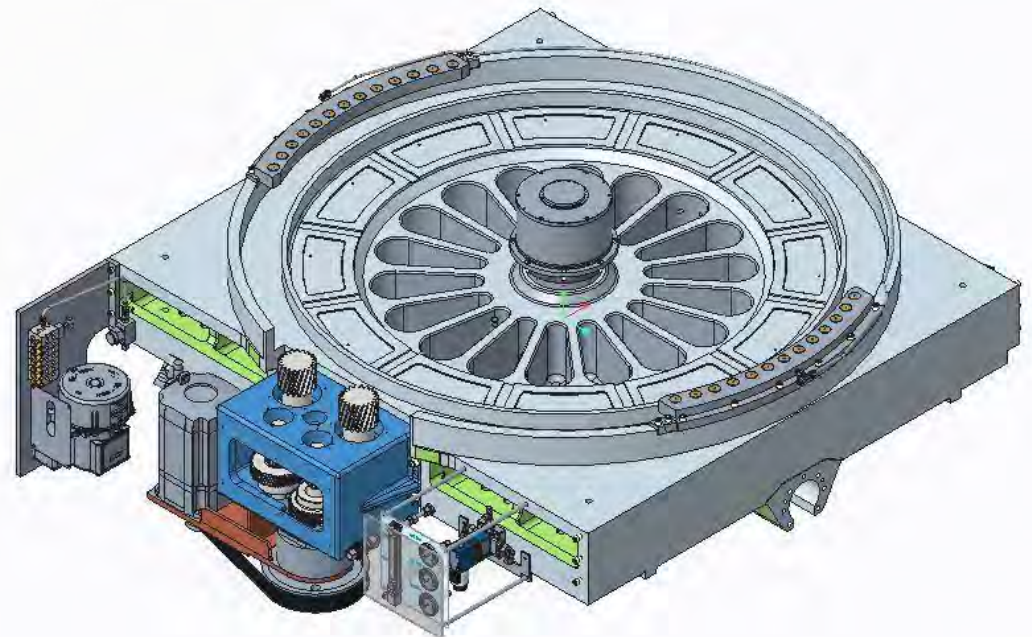
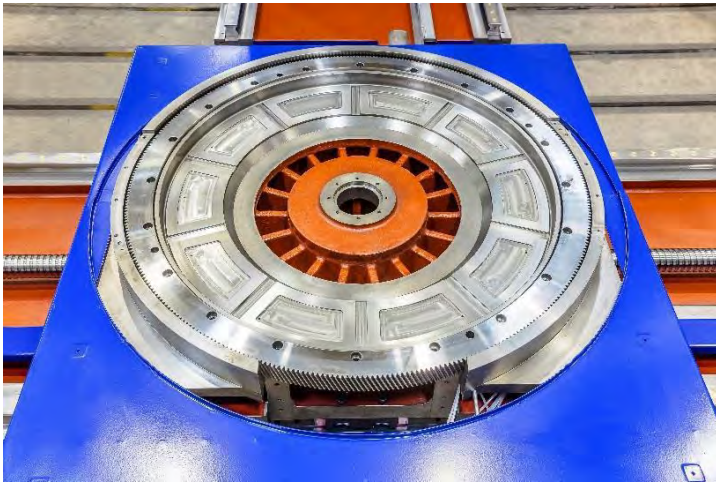

Technical characteristics

Automatic Tool Changer for 60 tools with pick-up Heads station



MAUSA

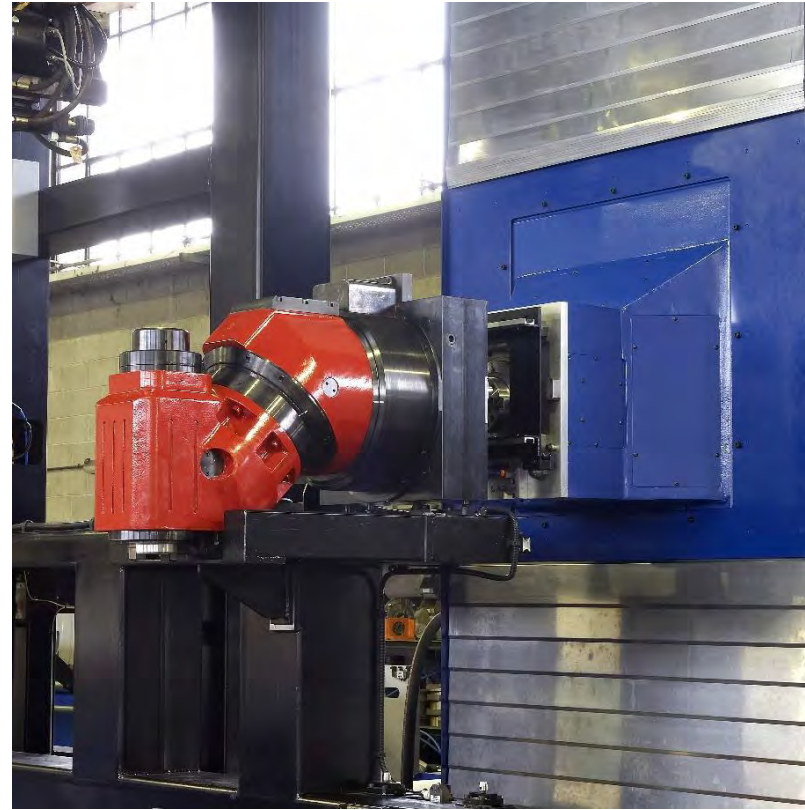

Maximum tool diameter	4.9"
Maximum tool diameter (without adj)	9.8"
Maximum tool length	2.6"
Maximum tool weight	77.2 lbs

Layout example (FV 101T – subsea)

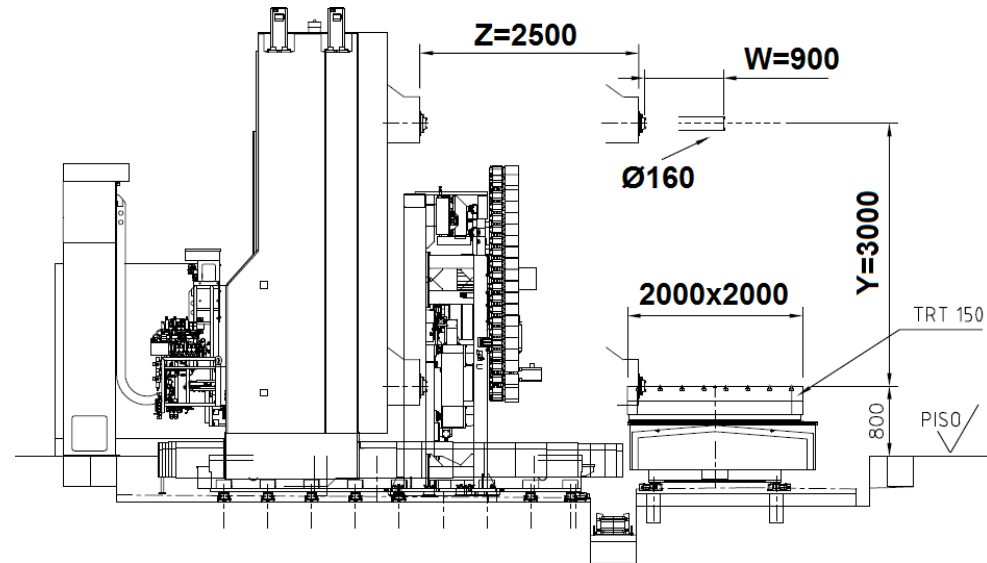
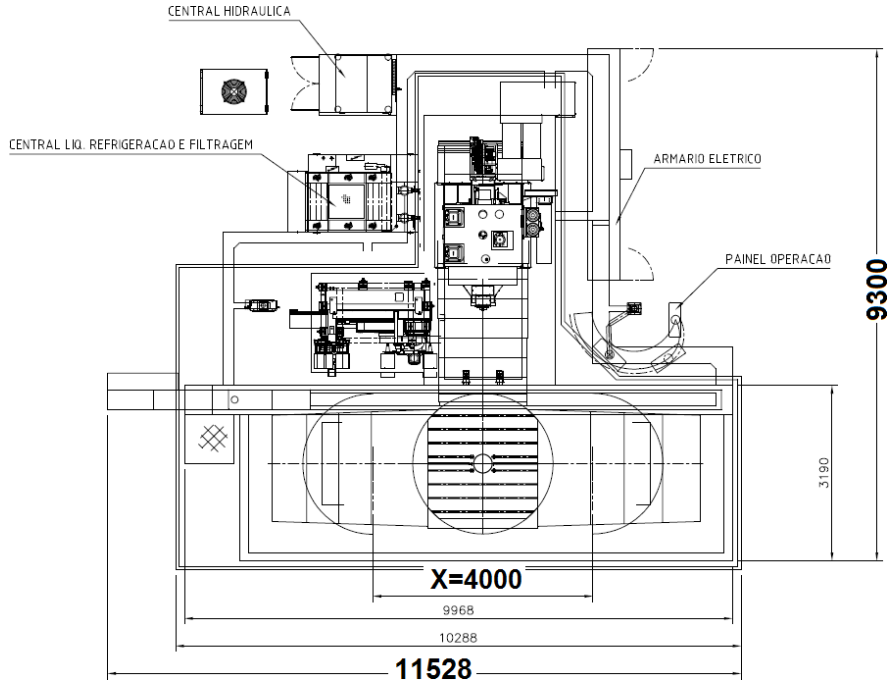

Dimensions in millimeters

FVM 100T aerospace “T -Type” Milling Machine



Technical specifications

M

MAUSA

		FVM 100 Aerospace
Table longitudinal travel (X axis)	in	157.5
Milling Head vertical travel (Y axis)	in	78.7
Column transversel travel (Z axis)	in	59.1
Spindle Power S1-100% (S6-40%)	HP	44.3 (56.4)*
A and C axis positioning (Milling Head)	degrees	continuous
A axis travel	degrees	+/- 110°
C axis travel	degrees	+/- 360°
Table surface	in	78.7 x 157.5
Table load capacity	lbs	11,023
Spindle nose	HSK	HSK 63*
Max speed	rpm	18,000*
Nominal torque S1-100%	in lbf	487*
Rapid traverse X, Y and Z	ipm	1,378

* Values depend on the type of milling head

Technical characteristics

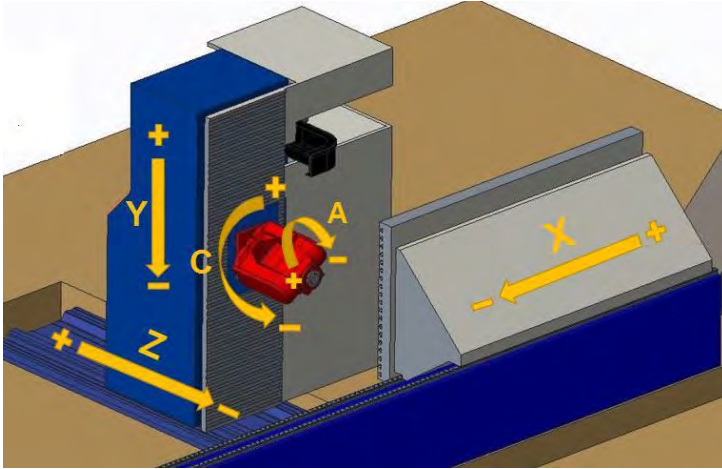

The FVM 100T Aerospace CNC Milling Machine, 5 axes, was designed to meet the high requirements required in the machining of components and structures in the aerospace market.

It has a structural concept that provides high efficiency of the processes involved in the manufacture of these components, both in its Technical specifications, as well as in its ergonomics and mechanical design, which facilitate the operations of setup, loading / unloading, measurements and chip output.

It was designed to perfectly adapt heads with double angular movements, C and A axes, as well as motor spindles with rotations and powers compatible with the need for this application.

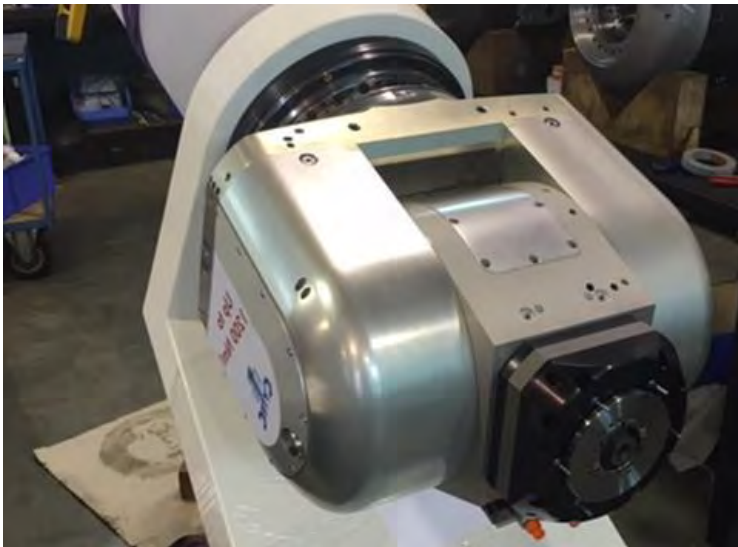

Technical characteristics

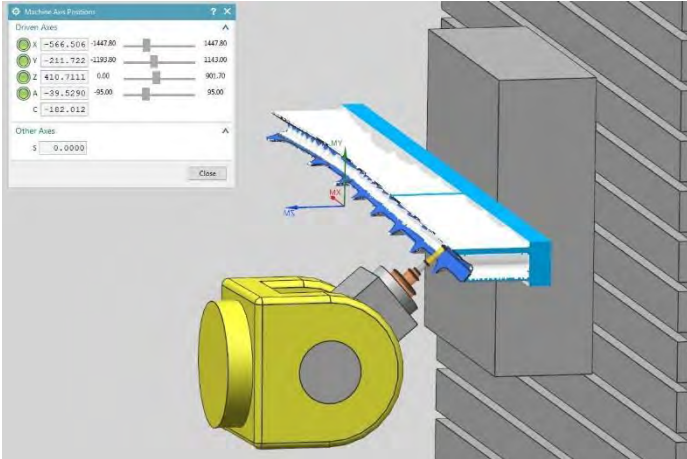

This combination provides the ability to perform smooth and uniform movements in complex interpolations in 5 axes. With a central carriage, responsible for the vertical movement (Y axis), supported on two front linear guides, 55mm and a linear back support guide, makes this set a monolithic structure with high rigidity.

Another longitudinal rail, has two linear roller guides, strategically fixed at different heights, forming an inclined plane of 45 degrees from the horizontal, which serves as a support for a 78.7 x 157.5 in table scales.



This arrangement provides excellent distribution of forces and stability during machining efforts. The table surface is 90 degrees from the ground and its movement in the direction of the X axis is transmitted through a ball screw and brushless servomotor. It has direct measurement on all axes, using optical



“Floor-Type” Machines

- **FVM 70/71**
- **FVM 80/81**
- **FVM 100/101**
- **FV 301**
- **FVM 501**

FVM 70 & FVM 71

“Floor -Type” Boring and Milling Machine



MAUSA

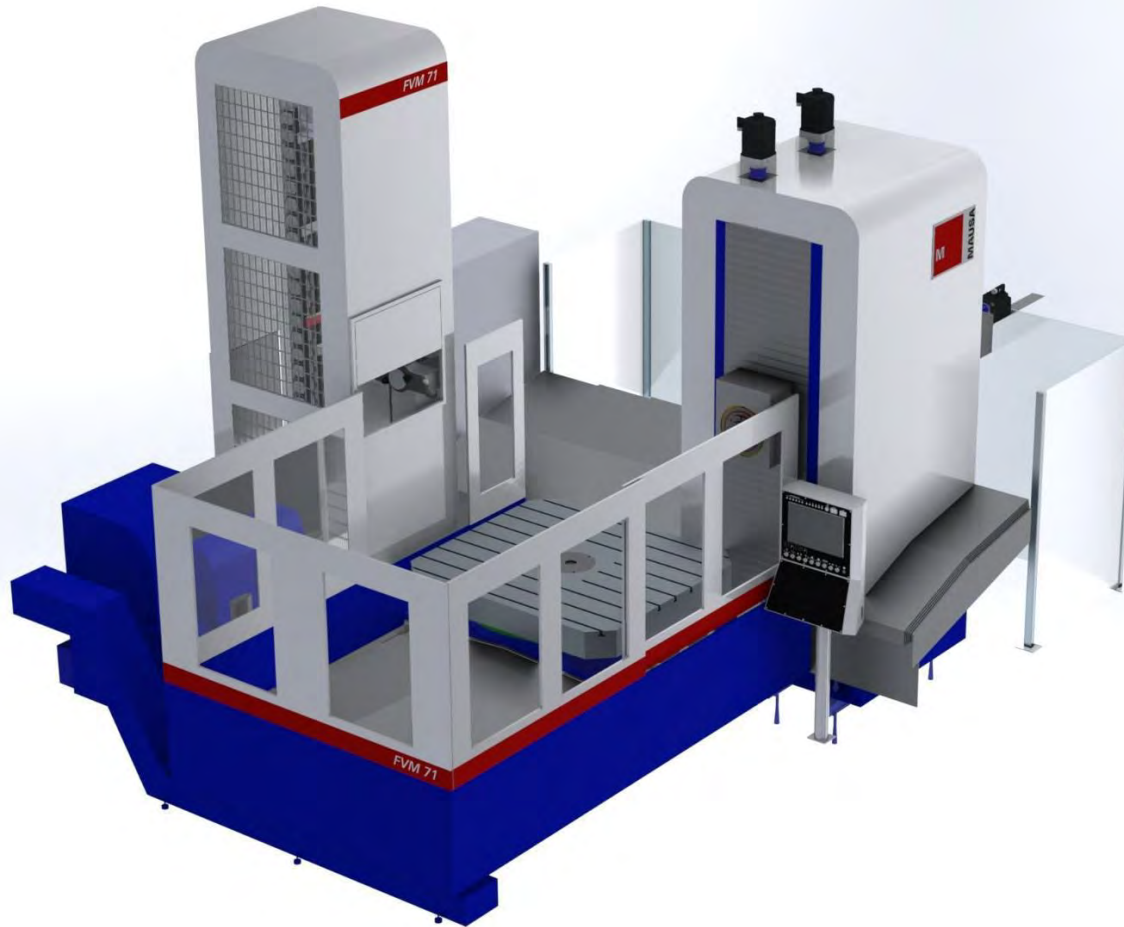

Technical specifications



		FVM 70*	FVM 71
Column longitudinal travel (X axis)	in	78.7	
Headstock vertical travel (Y axis)	in	63	
Table transversel travel (Z axis)	in	63	
Boring spindle axial travel (W axis)	in	NA	29.5
Spindle diameter (quill)	in	NA	5.1
Table surface	in	63 x 70.9	
Table load capacity	lbs	22,046	
Minimum angular increment (B axis)	degrees	0,001°	
Spindle Power S1-100% (S6-40%)	HP	54 (67.5)*	50 (62.5)
Spindle nose	ISO	50	
Max speed	rpm	5,000*	4,000
Milling Head positioning	degrees	1°*	OPT
Speed range (automatic)	unit	2	
Nominal torque S1-100%	in lbf	7,081*	12,515
Rapid traverse X / Z / Y	ipm	1,181	

* In the FVM 70 version, these values depend on the type of milling head

Technical characteristics



X = 1,181 ipm
Y = 1,181 ipm
Z = 1,181 ipm
W = 787 ipm
B = 7 rpm
Accel = 8.2 ft/s²

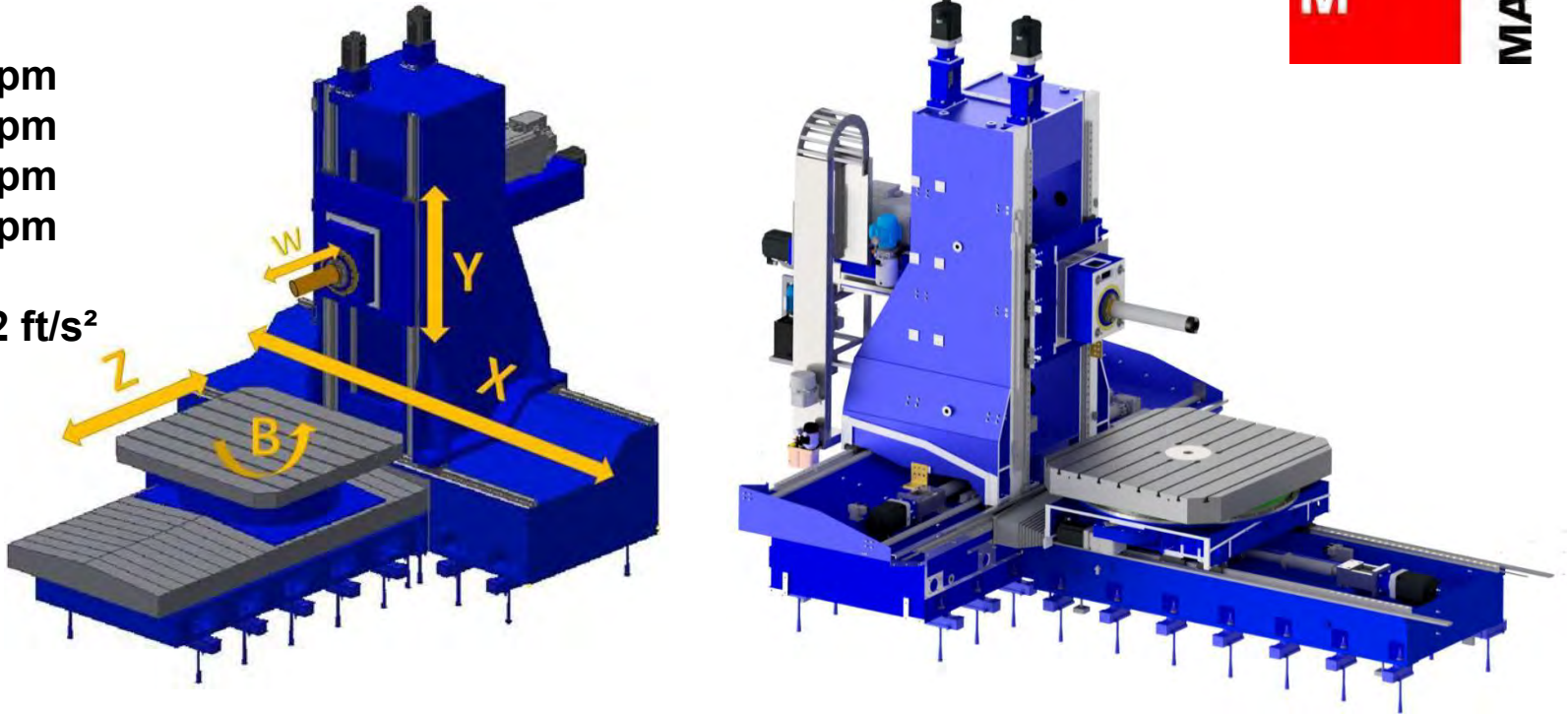

The CNC boring and milling machines FVM 70 and FVM 71 have been designed to meet the high requirements of precision and rigidity in machining complex parts that require productivity and flexibility.

FVM 71 is a machine with the robustness, strength and versatility of a Boring Machine, with productivity and performance of a Horizontal Machining Center.

Technical characteristics

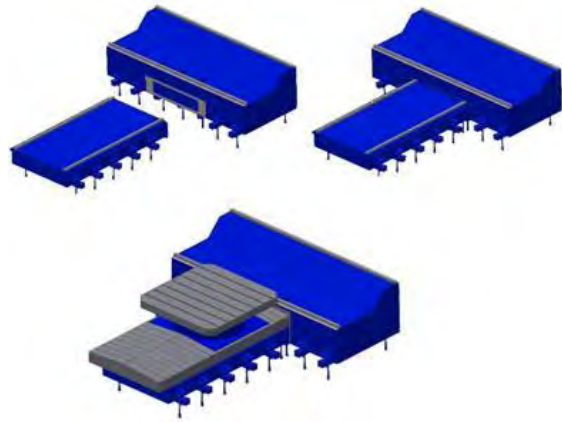

It has an innovative concept, where the column and table seats are mechanically coupled, forming a single, monolithic base, as the seat of all machine assemblies

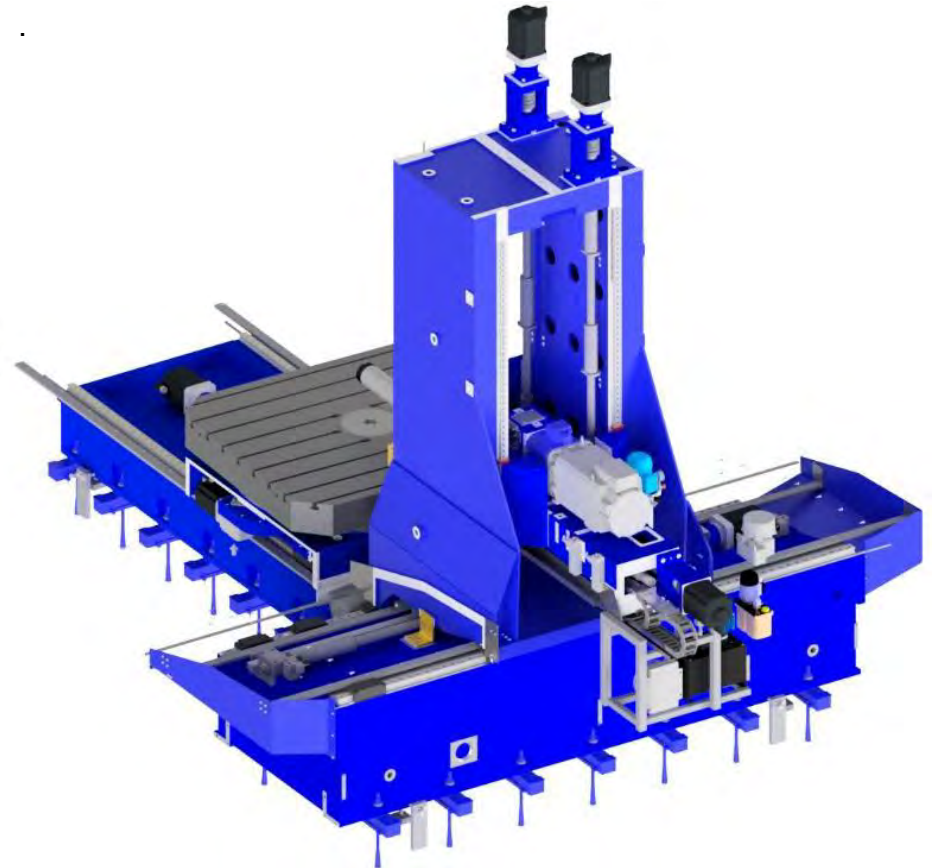
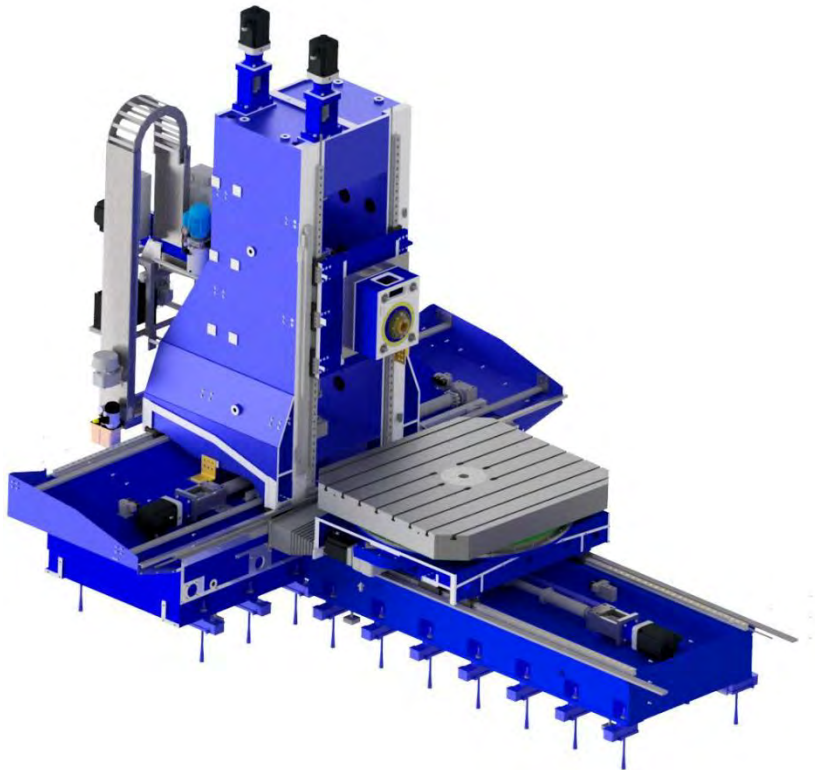

Technical characteristics



The column, which performs the movement in the longitudinal direction (X axis), is coupled through 6 (six) skids on two rails of linear roller guides, arranged at different levels, producing greater rigidity in the structure.

High dynamic stability, thanks to the low profile of the column and base, which provides excellent characteristics of ergonomics, rigidity, quality of machining and easy maintenance.

The machine base is widely supported, providing balance and stability during machining.

It has direct measurement on all axes, using optical scales.

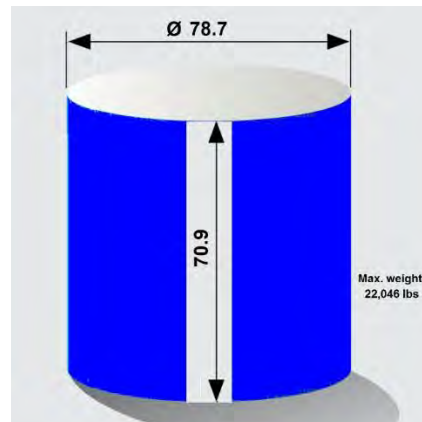

Excellent relationship between machining capacity (diameter, height and weight) and machine footprint.

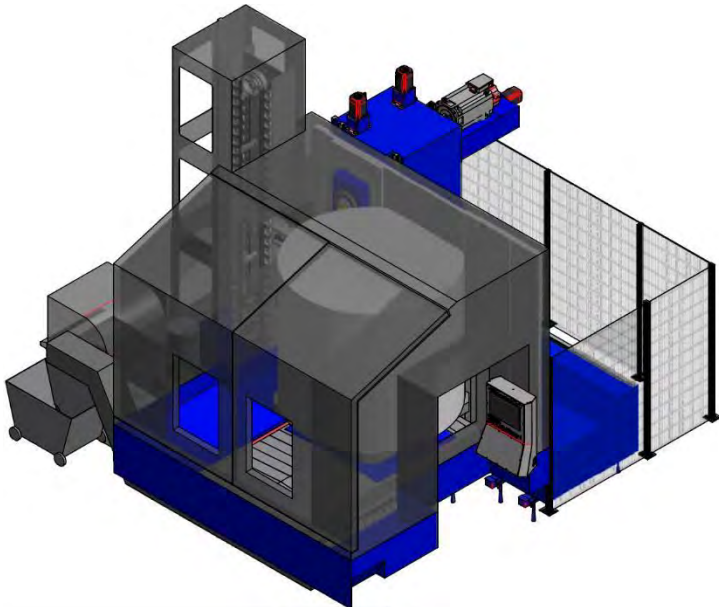
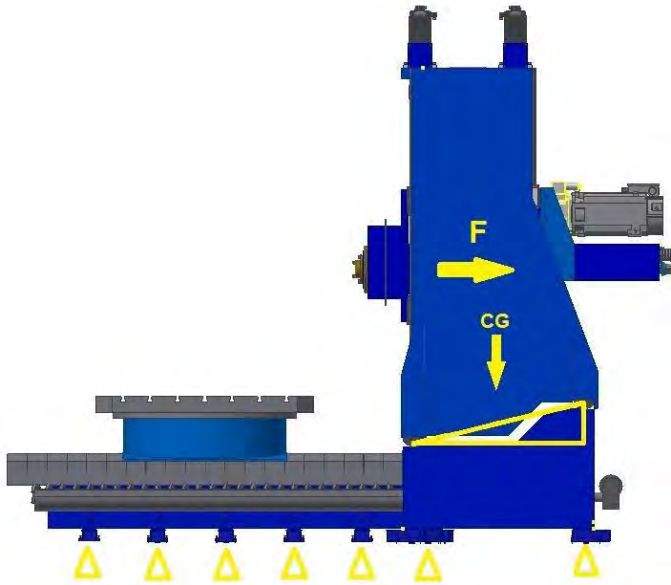

Technical characteristics



“Box in Box” concept

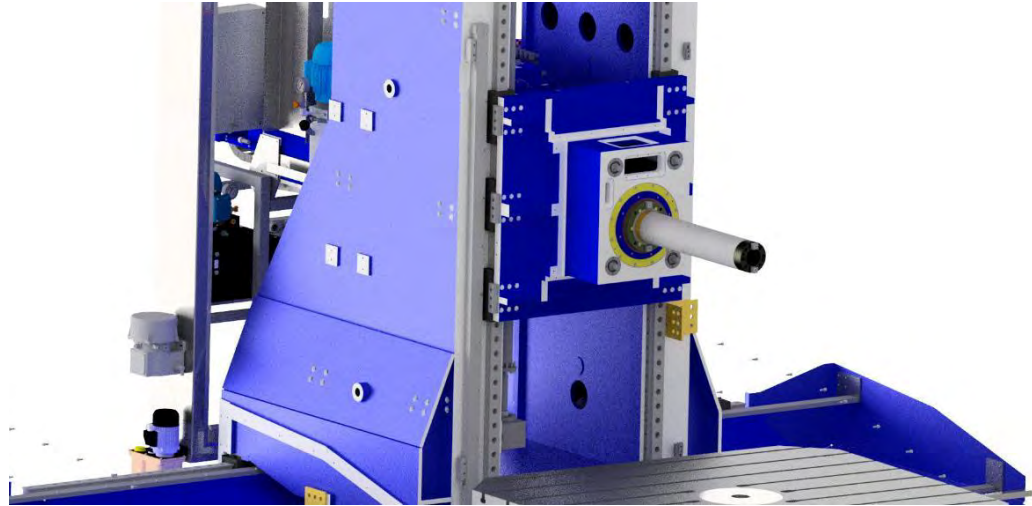

The headstock is positioned in the center of the double-walled column, in the “Box in Box” concept, having two front and two rear guides, providing great geometric stability and high rigidity, responding uniformly to machining forces, regardless of cutting directions and directions.

The face is mechanically prepared to receive Milling Heads.

Through the design of the headstock structure, the face of the spindle is projected towards the front of the column, improving the positioning and the reach of the tools in relation to the table.

The spindle $\varnothing 5.1$, located inside the headstock, is made of forged and tempered alloy steel and assembled with high precision ball bearings

The lubrication is achieved by means of a special system, air-oil, lubricating and cooling the entire assembly, allowing uninterrupted

Technical characteristics

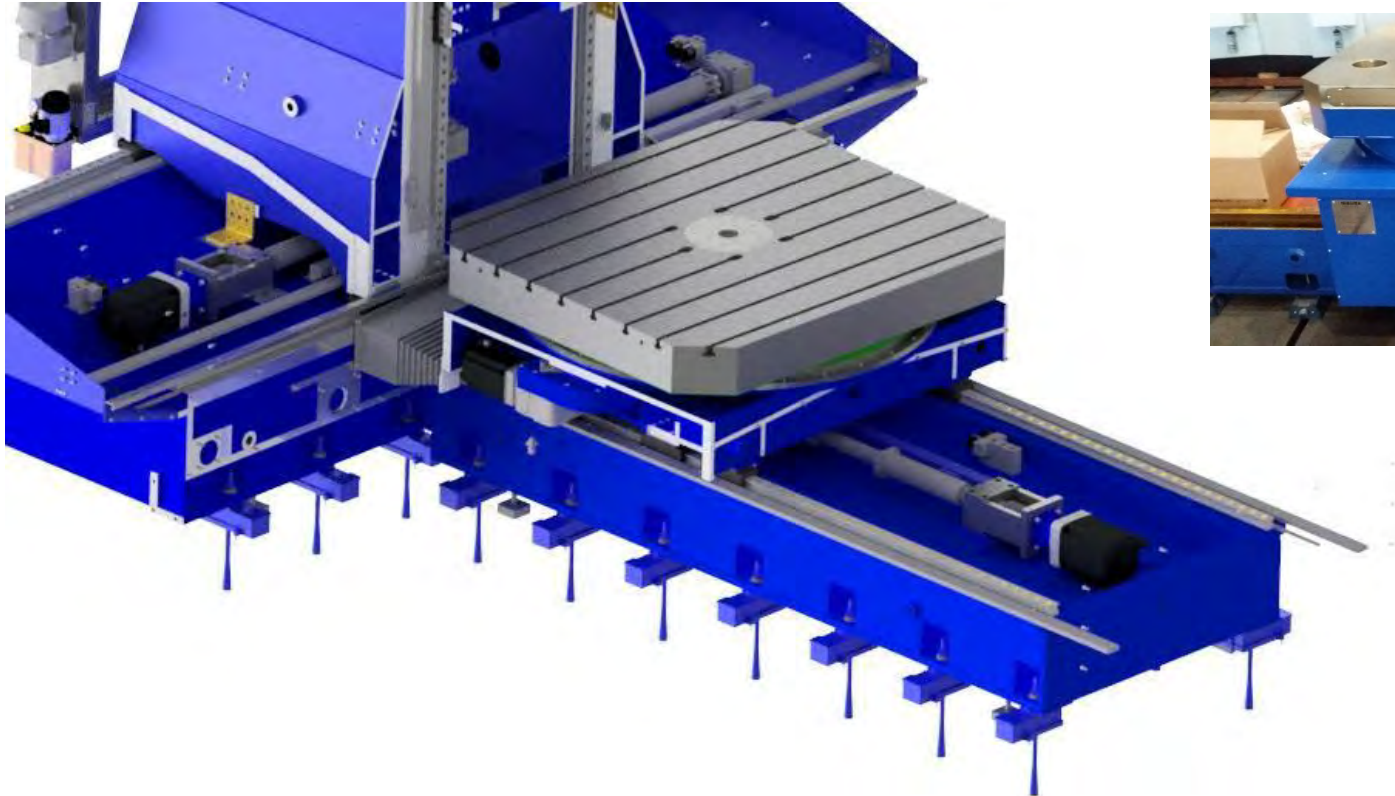

The rotational movement of the table, axis B, on the base, is supported by a hydrostatic system, which consists of a pressurized oil film permanently between the surfaces, eliminating the contact, as well as the consequent wear between the parts.

It has linear movement in the transverse direction (Z axis), transmitted through a servomotor and recirculating ball screw.

Technical characteristics

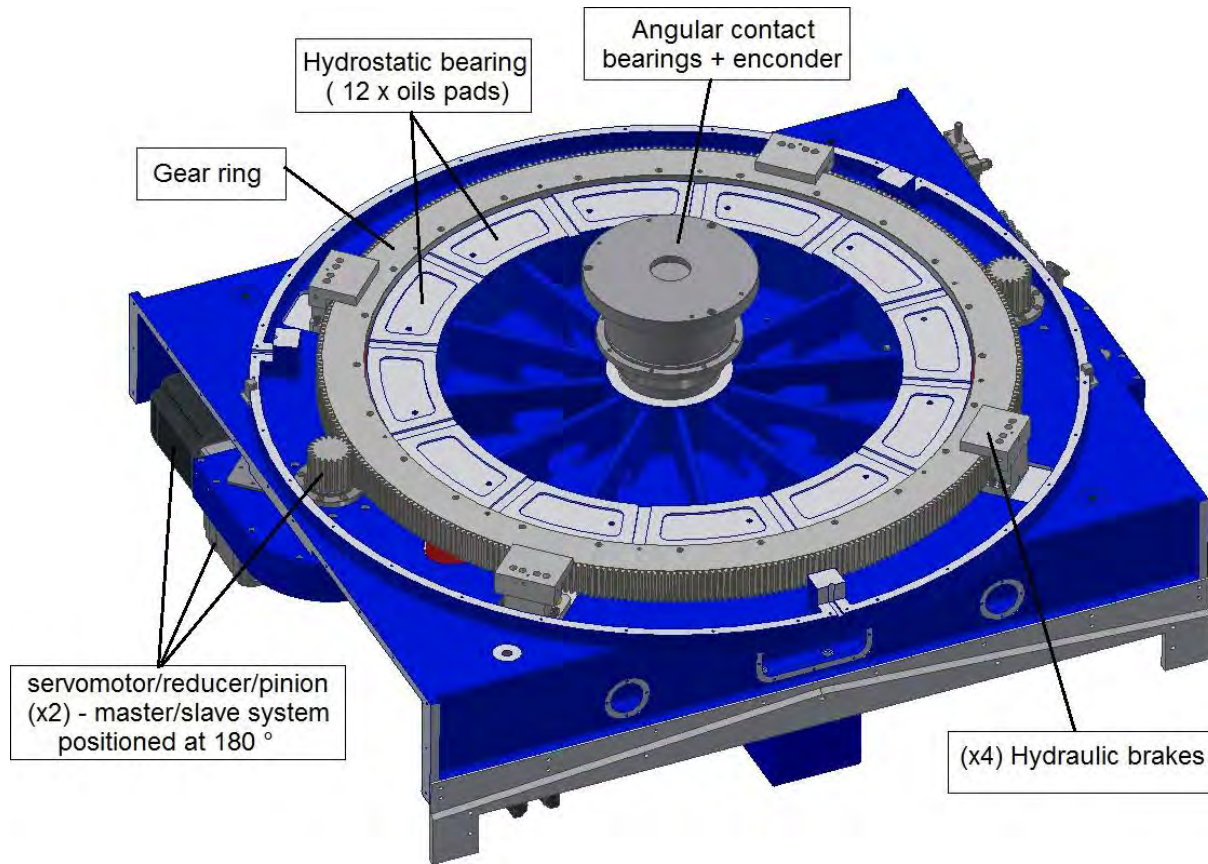

The extremely low friction eliminates the stick-slip effects, allowing the precision of angular positioning of the 18,000 pulse encoder to be faithfully reproduced in the workpiece.

The transmission is made by two sets of servomotors and planetary gearboxes and a toothed crown fixed to the table.

Technical characteristics



Available Positions	unit	60
Distance between pockets center	In (mm)	5.1 (130)
Max Tool Diameter mm 125	In (mm)	4.9 (125)
Maximum tool diameter (without adj)	In (mm)	9.8 (250)
Maximum Tool Length	In (mm)	23.6 (600)
Maximum tool weight	Lbs (kg)	66.1 (30)
Maximum load on ATC	Lbs (kg)	2,205 (1,000)
Maximum tool moment	Lb.in (Nm)	266 (30)

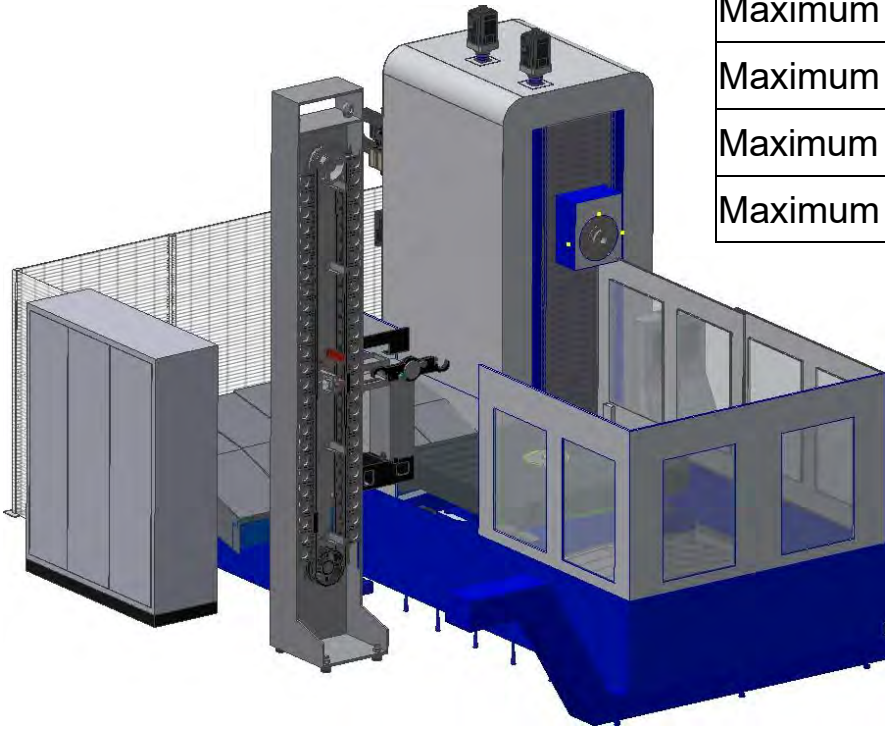

Technical characteristics

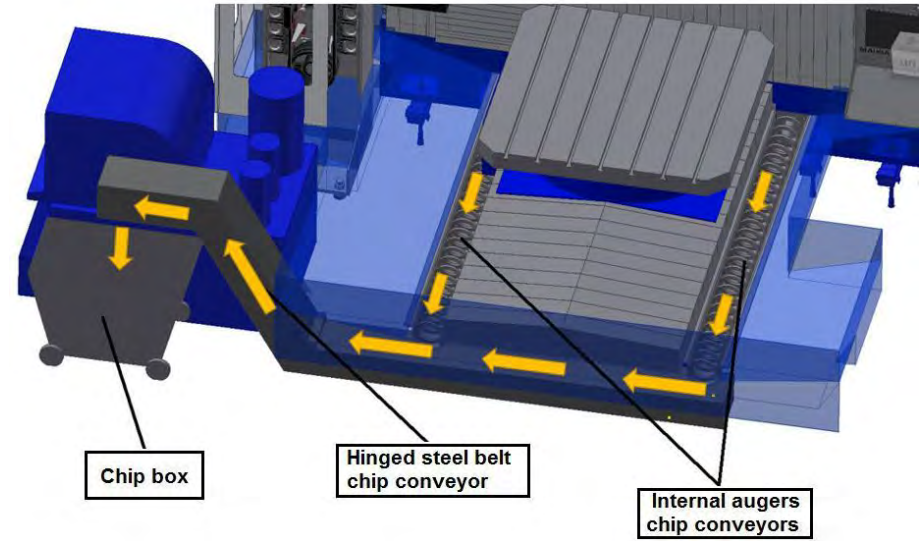
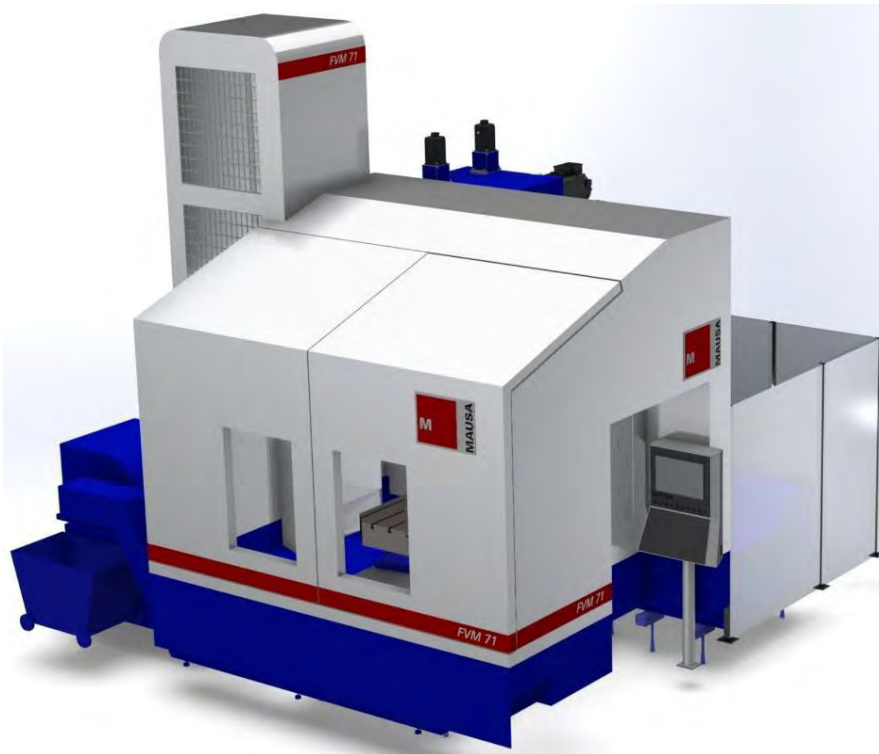

The chip removal system is highly efficient, as all chips produced during machining flow to the sides of the table and are transferred through two augers conveyors to a front hinged steel belt chip conveyor.

Layout example (FVM 71 with ATC)

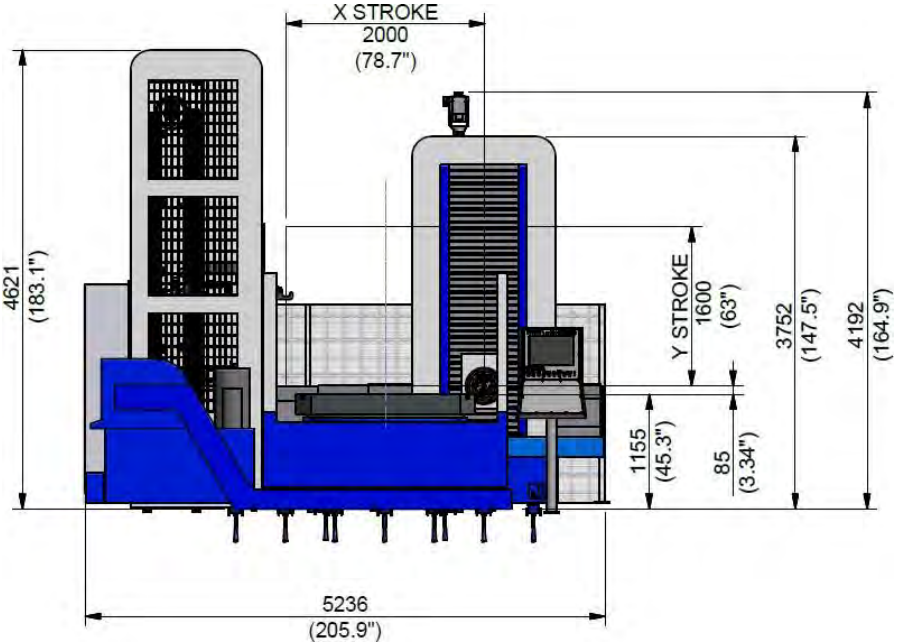
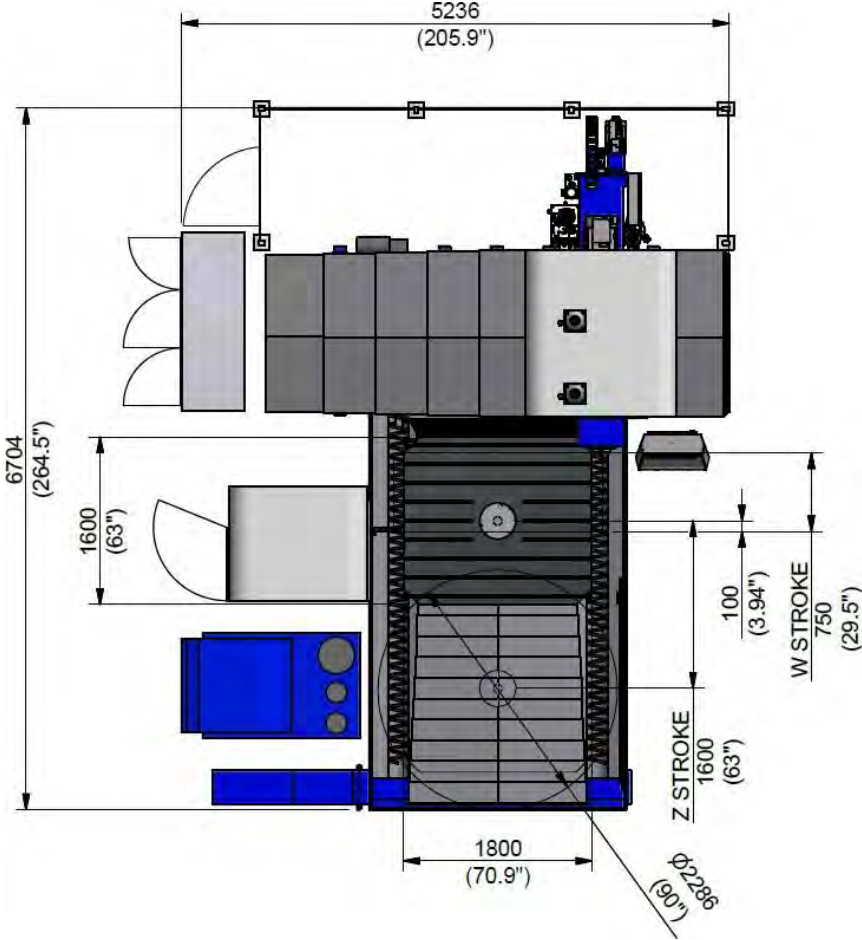

Dimensions in millimeters and inches

FVM 80 & FVM 81

“Floor -Type” Boring and Milling Machine



Technical specifications



		FVM 80*	FVM 81
Column longitudinal travel (X axis)	in	118.1 + n x 39.4	
Headstock vertical travel (Y axis)	in	59 / 98.4	
RAM transversel travel (Z axis)	in	51.2	
Boring spindle axial travel (W axis)	in	NA	27.6
Spindle diameter (quill)	in	NA	5.1
Table surface	in	70.9 x 70.9 up to 78.7 x 118.1	
Table load capacity	lbs	33,069 or 66,139	
Linear travel of Table (V axis)	in	39.4 up to 118.1	
Minimum angular increment (B axis)	degrees	0,001°	
Spindle Power S1-100% (S6-40%)	HP	54 (67.5)*	50 (62.5)
Spindle nose	ISO	50	
Max speed	rpm	5.000*	4.000
Milling Head positioning	degrees	1°*	OPT
Speed range (automatic)	unit	2	
Nominal torque S1-100%	in lbf	7,081*	12,515
Rapid traverse X / Z / Y	ipm	787	

* Values depend on the type of milling head

Technical characteristics

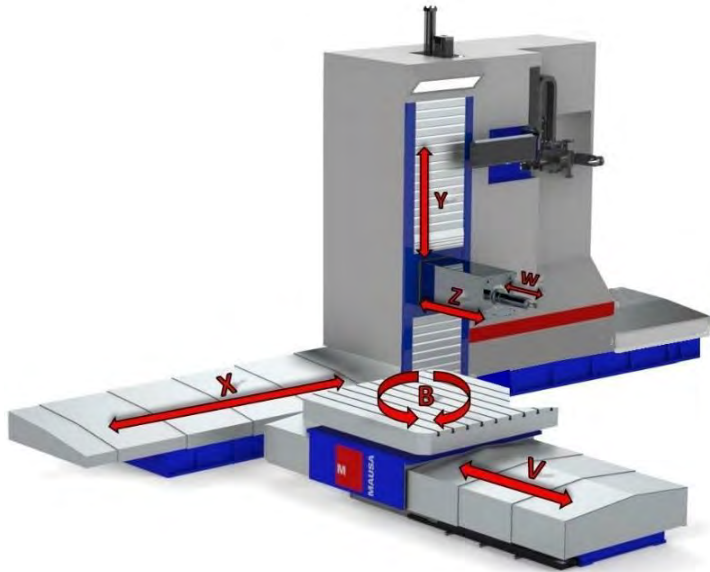

Machines with flexible architecture, facilitating different configurations and customizable configurations, allowing different solutions, from simple milling and drilling applications to sophisticated automation systems, such as 5-axis version, multitasking, molds & dies, pendulum concept, automated loading and unloading, palletizing, etc....

It has high stability and performance due to the low center of gravity and precise dimensioning

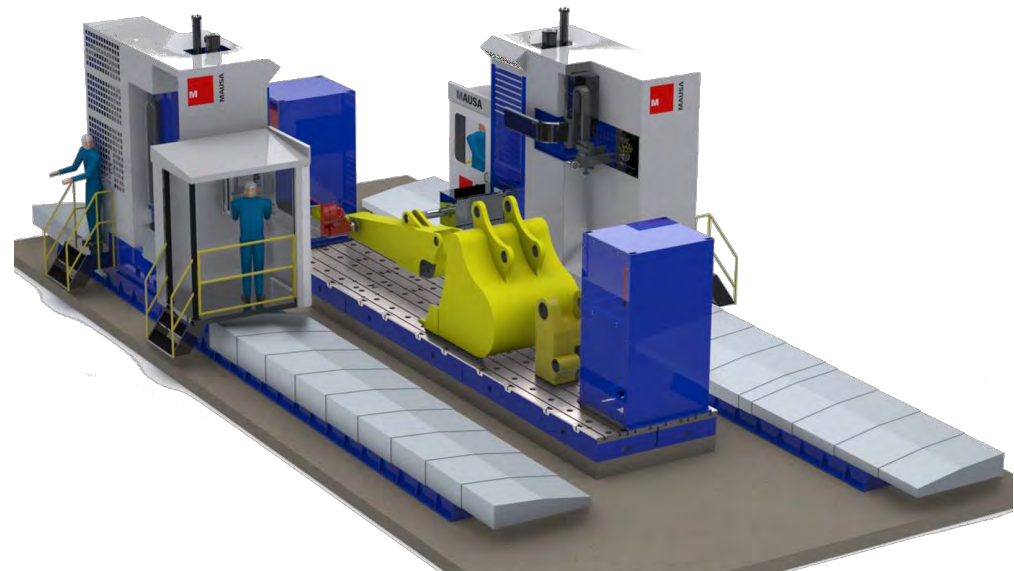

Technical characteristics

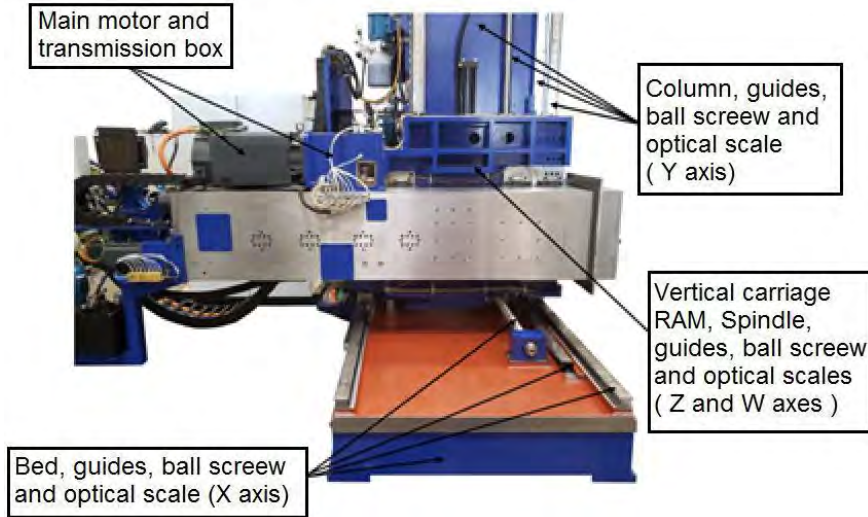

Excellent ratio of power, rpm and torque, with 2 speed ranges with automatic switching via CNC.

Stroke, force and feed specifications strictly suitable for the most varied applications for this machine size.

Two linear 65mm roller guides and 6 displacement skids are mounted on the base (X axis), which guarantee rigidity and uniformity of movement of the column.

The column and its base are manufactured in a single piece, being a monolithic structure with high rigidity.



Technical characteristics



The RAM carriage is fixed using two 55 mm linear roller guides, with 6 skids positioned in order to ensure maximum rigidity of the assembly.

The vertical movement (Y axis) of the RAM carriage, in the column, is performed by a servomotor with precision planetary gearbox and transmitted through recirculating ball screw.



The mass of the set is balanced through an accumulator and hydraulic cylinder, providing smooth and uniform movements, strongly contributing to the quality of finishing machining.

Technical characteristics

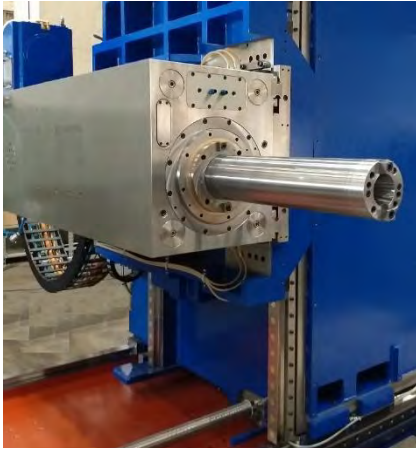

The spindle \varnothing 5.1 in, located inside the RAM, is made of forged and tempered alloy steel and assembled with high precision ball bearings.

The lubrication is achieved by means of a special system, air-oil, lubricating and cooling the entire assembly, allowing uninterrupted work at high rpm

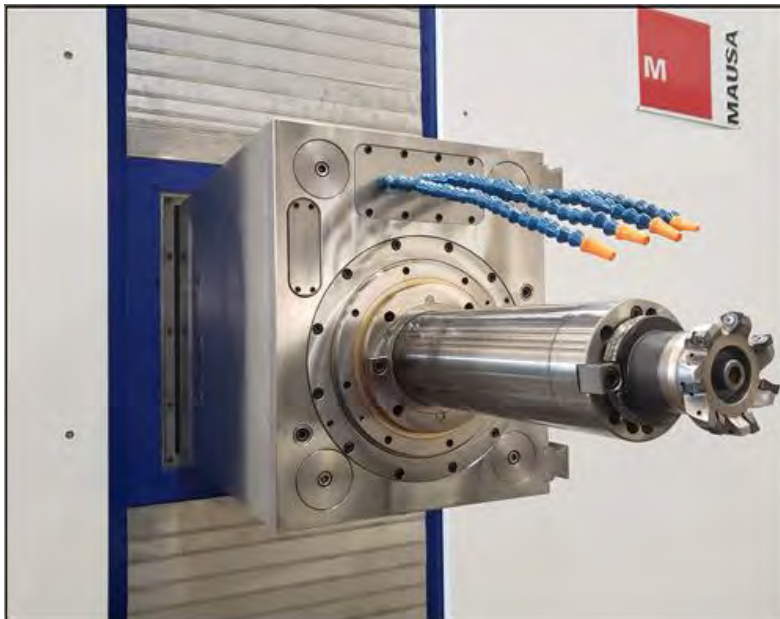

The RAM face is mechanically prepared to receive optional Milling Heads, with automatic change.



Technical characteristics

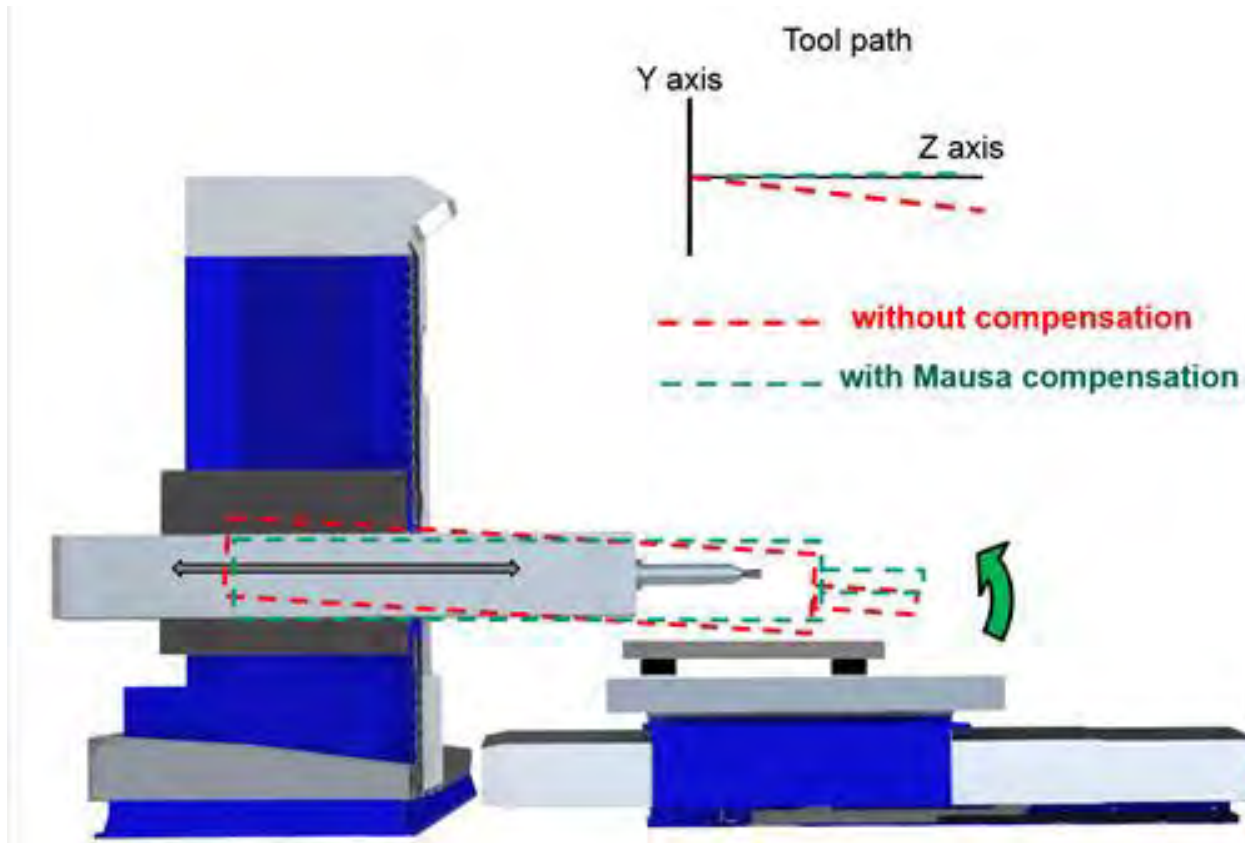

Due to the physical and natural effect, all RAM undergoes a small “drop” in relation to its initial level, as it is projected out of its bearing.

All Mause boring machines with RAM have built-in systems to mechanically and automatically correct these deviations from the RAM, in real time, regardless of the direction of movement, moving forward or backward and with or without a milling head installed.

Layout example (FVM 81, X= 118"and Y= 99")

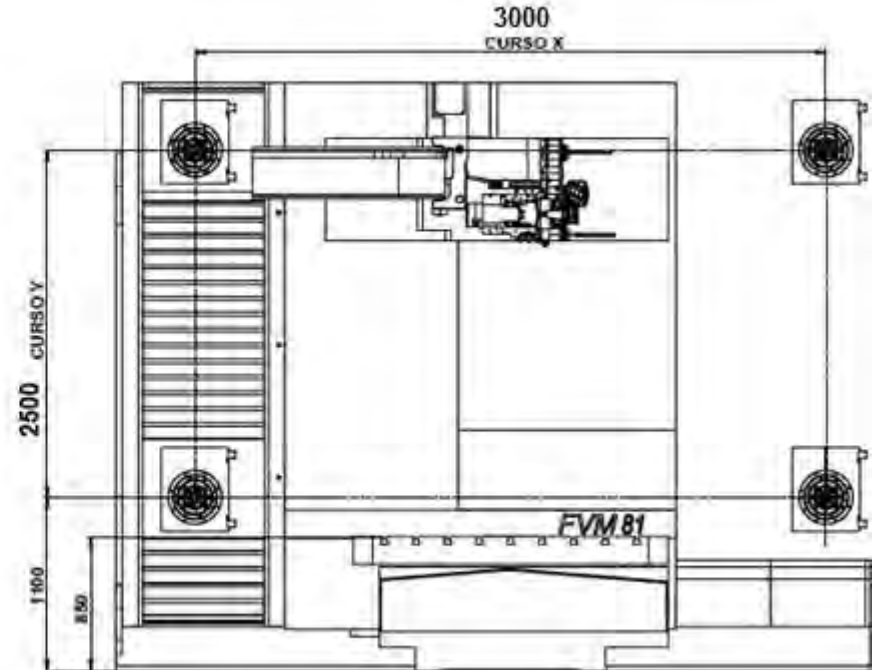
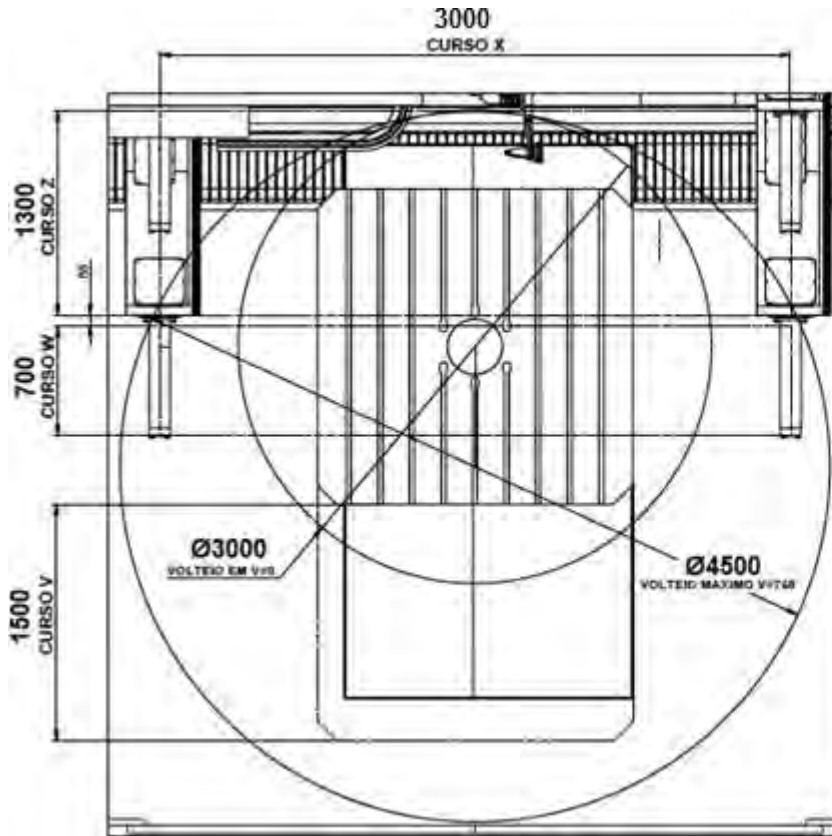

Dimensions in millimeters

Layout example (FVM 81, X= 315" + 2 tables)



MAUSA

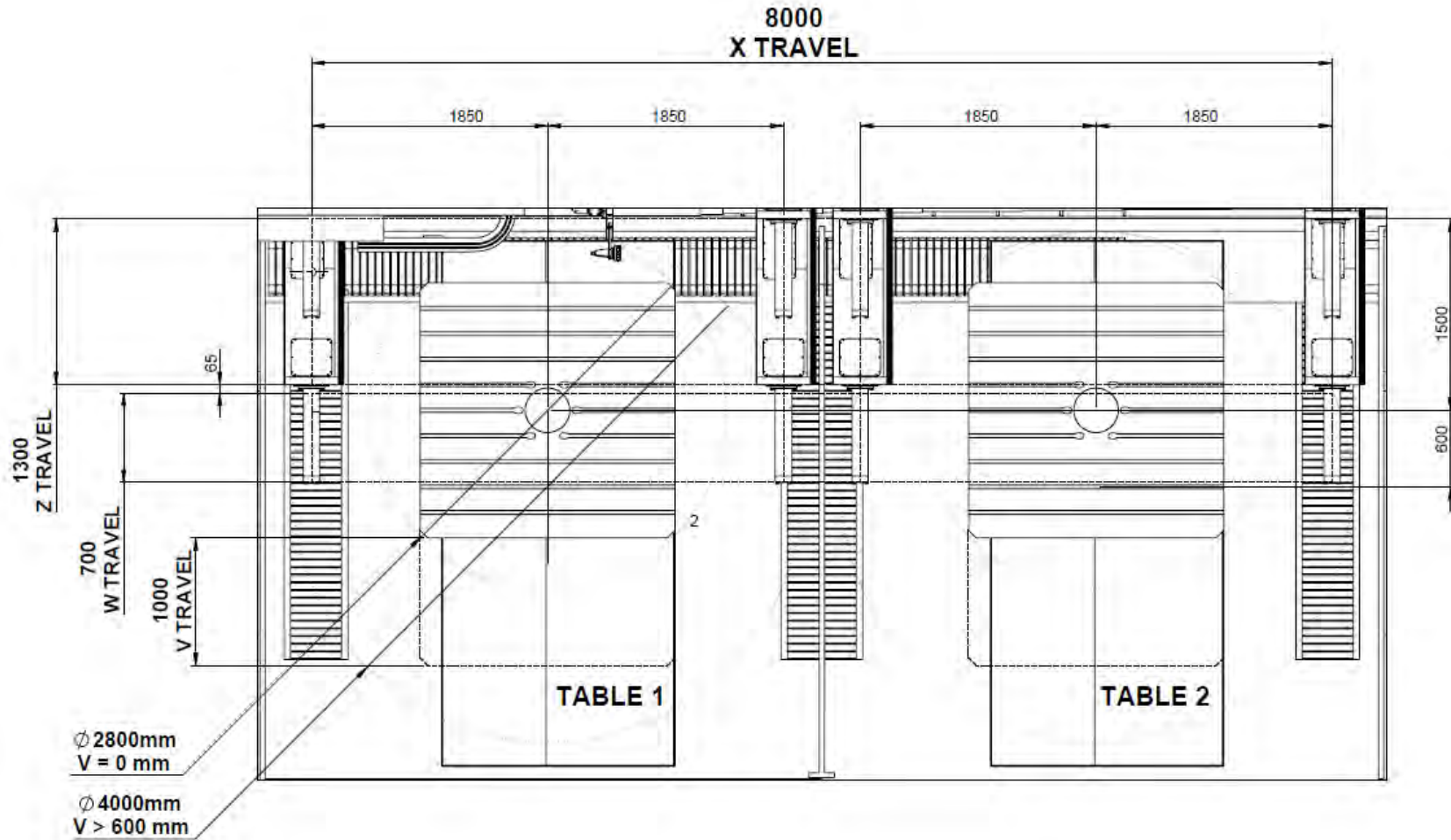

Dimensions in millimeters

Layout example (FVM 80 – 5X)



MAUSA

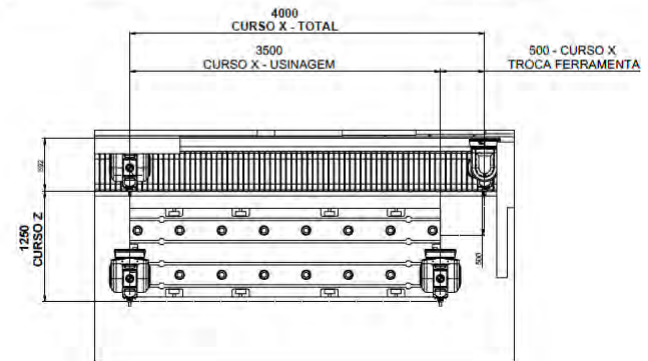
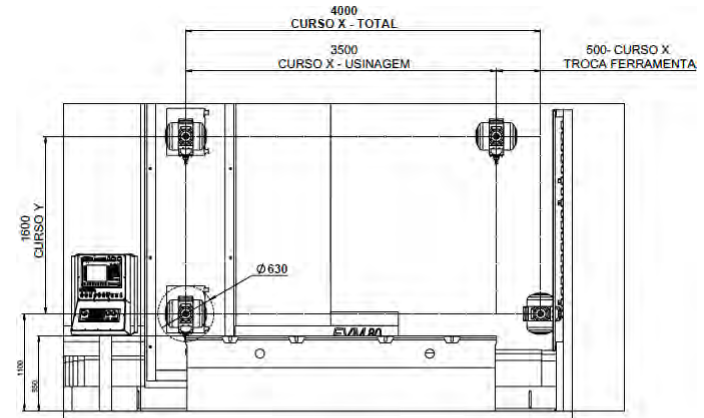
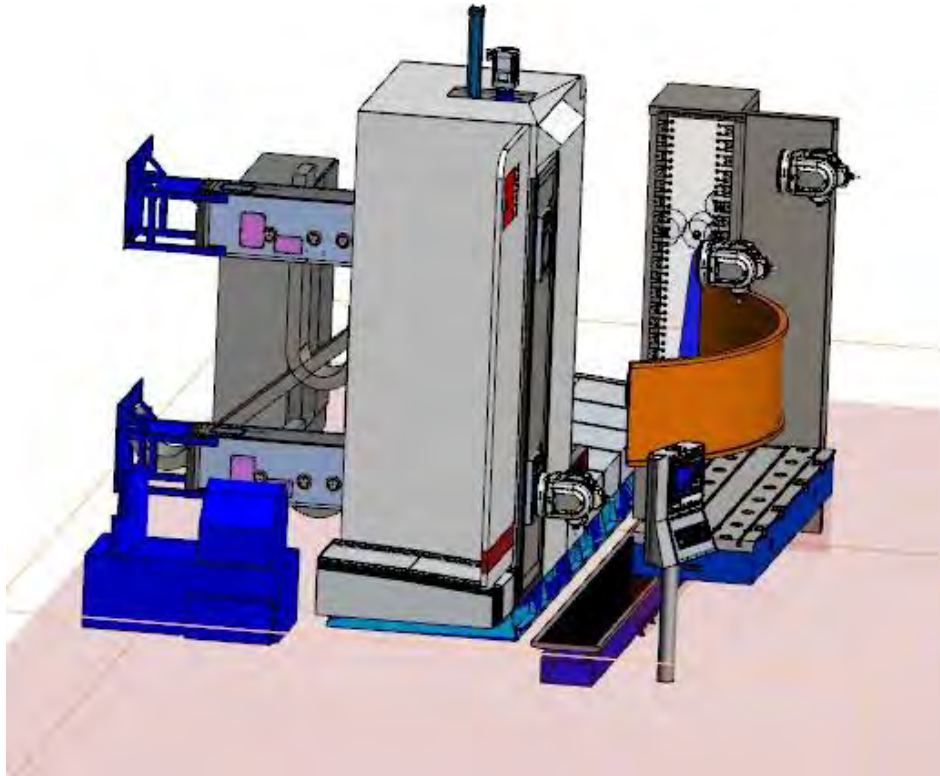

Dimensions in milimeters

FVM 100 & FVM 101

“Floor -Type” Boring and Milling Machine



Technical specifications



		FVM 100*	FVM 101
Column longitudinal travel (X axis)	in	157.5 + n x 39.4	
Headstock vertical travel (Y axis)	in	98.4 to 118.1	
RAM transversel travel (Z axis)	in	49.2	
Boring spindle axial travel (W axis)	in	NA	27.6
Spindle diameter (quill)	in	NA	5.1
Table surface	in	70.9 x 70.9 up to 78.7 x 118.1	
Table load capacity	lbs	33,069 or 66,139	
Minimum angular increment (B axis)	degrees	0,001°	
Linear travel of Table (V axis)	in	39.4 up to 118.1	
Spindle Power S1-100% (S6-40%)	HP	54 (67.5)*	50 (62.5)
Spindle nose	ISO	50	
Max speed	rpm	5,000*	4,000
Milling Head positioning	degrees	1°*	OPT
Speed range (automatic)	unit	2	
Nominal torque S1-100%	in lbf	7,081*	12,515
Rapid traverse X / Z / Y	ipm	1,378 / 1,378 / 591	

* Values depend on the type of milling head

Technical characteristics



The longitudinal movement of the column, X axis, is transmitted through two sets of servo motors and planetary reducers of high precision, in the “master / slave” configuration, producing uniform and smooth movements, eliminating “backlash” in the reversals movement.

The FVM 100 has a rapid feed of 1,378 ipm. The vertical movement, Y axis, is made by servomotor, reducer and ball screw, having a hydraulic counterweight system, consisting of hydraulic cylinder and accumulators that provide smooth reversals, improving the finishing of machining and reducing precision errors during the change of coordinate quadrant.



Technical characteristics

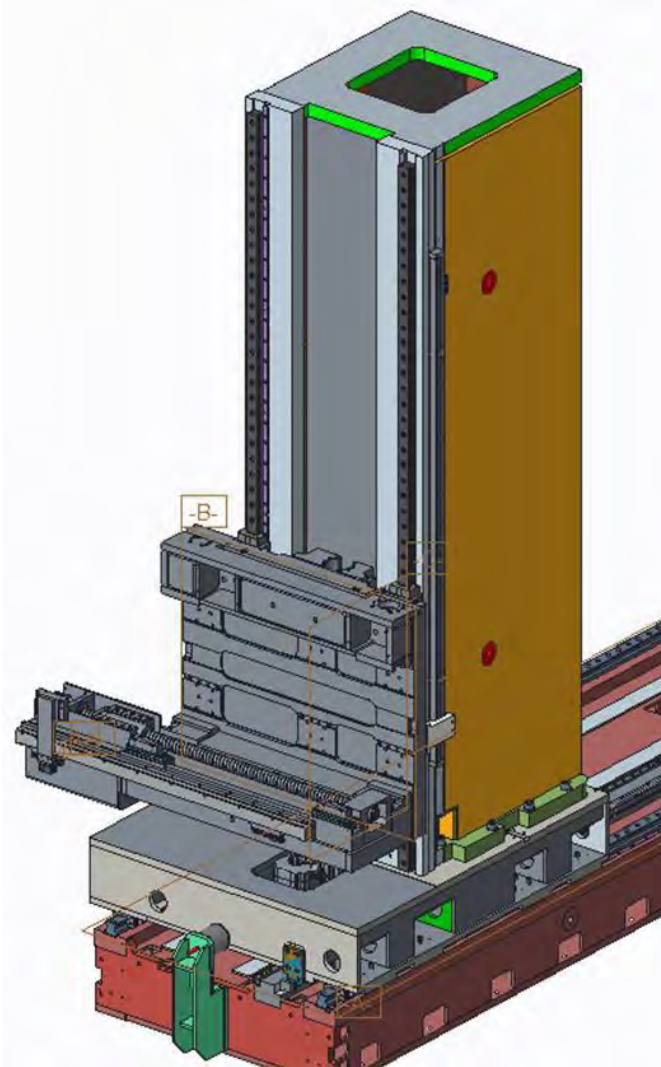

The RAM carriage has an “L” shape, in order to support the RAM laterally through linear guides and at the bottom by high precision linear bearings, which act on a tempered surface of the assembly, increasing its mechanical rigidity.

In addition to the linear guides and bearings, the RAM movement, Z axis, has a system formed by 14 turcite shoes, hydraulically activated when in machining cycles, adding damping properties to the assembly and reducing the possibility of machining vibrations.

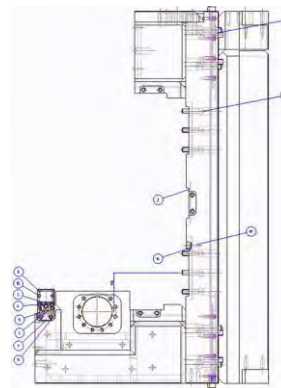

Technical characteristics



The rotational movement of the table of 33,069 or 66,139 lbs, axis B, on the base, is supported by a hydrostatic system, which consists of a pressurized oil film permanently between the surfaces, eliminating the contact, as well as the consequent wear between the parts .

Transmission is performed by a servomotor and two preloaded pinions, eliminating backlash clearance issues

The linear movement, V axis, is done through a servomotor and recirculating ball screw.

In the CNC boring version, the FVM 101 has a \varnothing 5.1 in spindle, which can be configured with automatic milling heads, depending on your application.

Can be equipped with a “pick-up” station for automatic head changing.

Technical characteristics



In the CNC Milling version, the FVM 100 is equipped with an Automatic Milling Head, directly driven by a high performance motor, providing 54 HP, without the need for mechanical transmissions. This motor has two rpm / torque ranges, via winding arrangement.

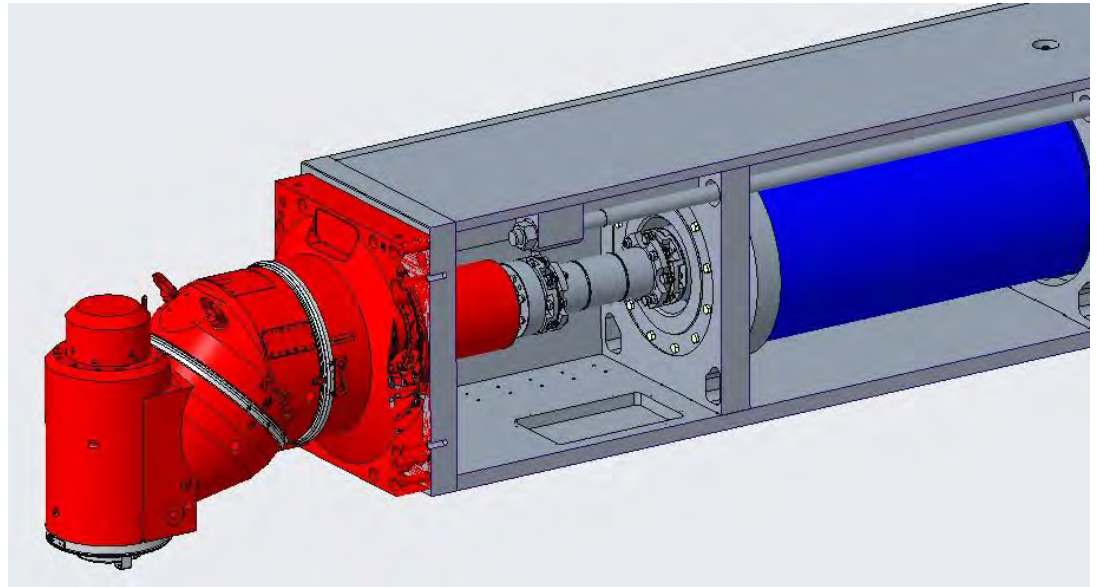
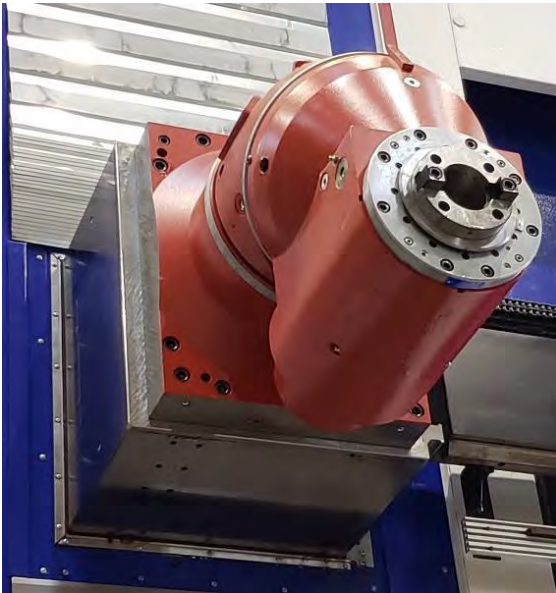

Both the motor and the head have independent external cooling units, with coolant circuits for both sets, automatically controlling operating temperatures.

Layout example (FVM 100, X=315”)



MAUSA

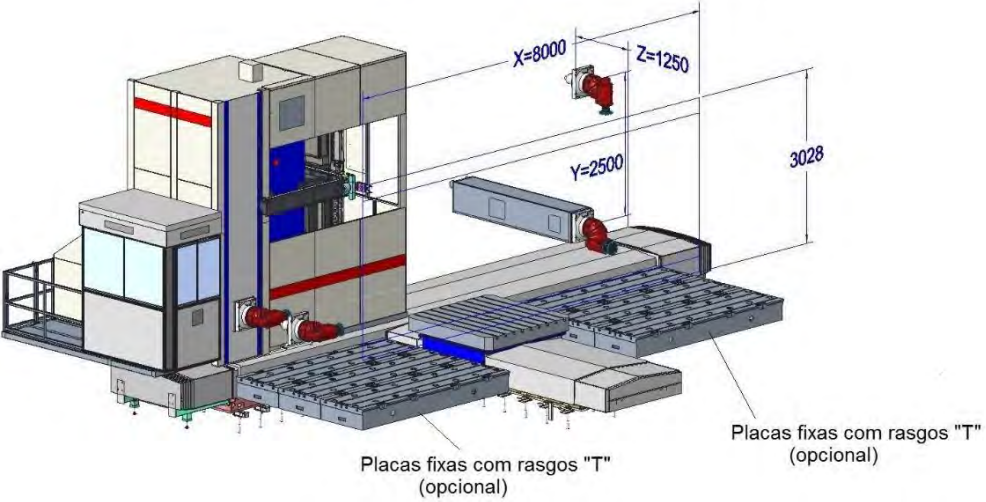
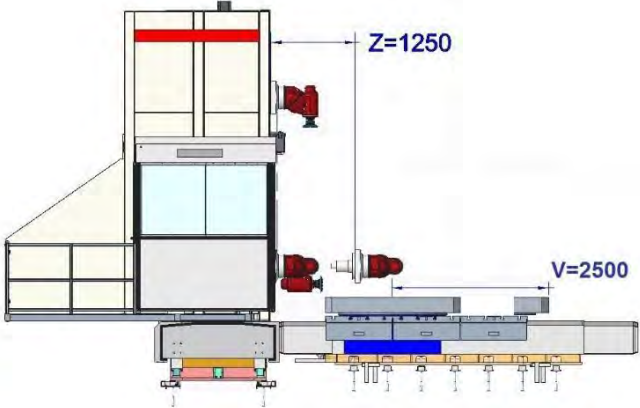
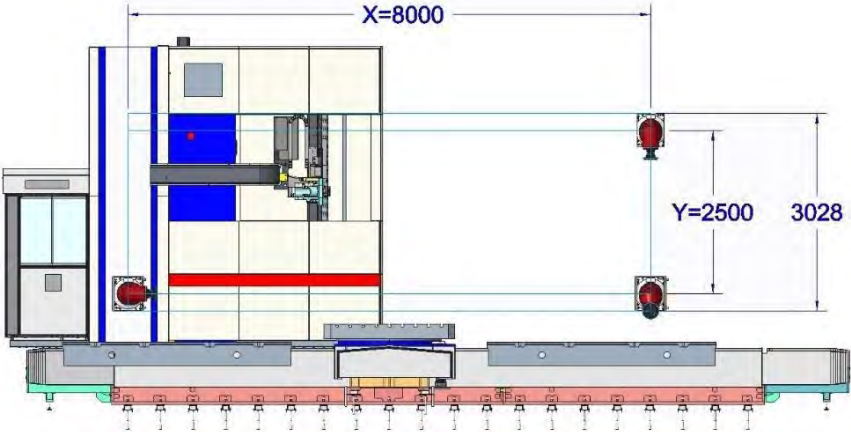

Dimensions in millimeters

FV 301

“Floor -Type” Boring and Milling Machine



Technical specifications



MAUSA

		FV 301
Column longitudinal travel (X axis)	in	236.2 + n x 39.4
Headstock vertical travel (Y axis)	in	118.1 / 157.5 / 196.9
RAM transversel travel (Z axis)	in	59
Boring spindle axial travel (W axis)	in	35.4
Spindle diameter (quill)	in	6.3
Table surface	in	70.9 x 70.9 up to 137.8 x 137.8
Table load capacity	lbs	66,139 / 132,277 / 220,462
Minimum angular increment (B axis)	degrees	0,001°
Linear travel of Table (V axis)	in	39.4 up to 118.1
Spindle Power S1-100% (S6-40%)	HP	86 (126)
Spindle nose	ISO	50
Max speed	rpm	3,000
Speed range (automatic)	unit	2
Nominal torque S1-100%	in lbf	24,190
Rapid traverse X / Z / Y	ipm	984

Technical characteristics

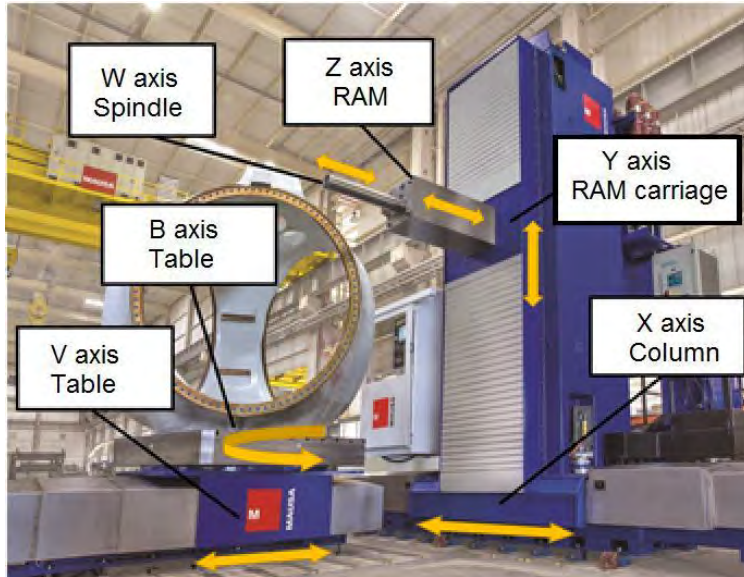

The CNC Boring Machine FV 301 has robust structure and design concepts, to meet a wide range of medium and large parts applications, which require high chip removal rates, combined with a high degree of precision.

On the base (X axis), two 65mm linear roller guides and twelve displacement skids are mounted, which guarantee rigidity and uniformity of movement of the column.

The forward force and speed are transmitted by two sets of servomotors and planetary gearboxes, helical rack and double pinions, strategically positioned on opposite sides of the column.



Technical characteristics



The spindle Ø 6.3 in, located inside the RAM, is made of forged and tempered alloy steel and assembled with high precision ball bearings

The lubrication is achieved by means of a special system, air-oil, lubricating and cooling the entire assembly, allowing uninterrupted work at high rpm

The RAM movement (Z axis) is supported by 16 sets of linear bearings, 8 of which are positioned at the front and 8 at the rear of the carriage, forming a single sliding bearing, with very low friction, high rigidity and low susceptibility to vibrations. The movement is driven by a servomotor and recirculating ball screw

Technical characteristics

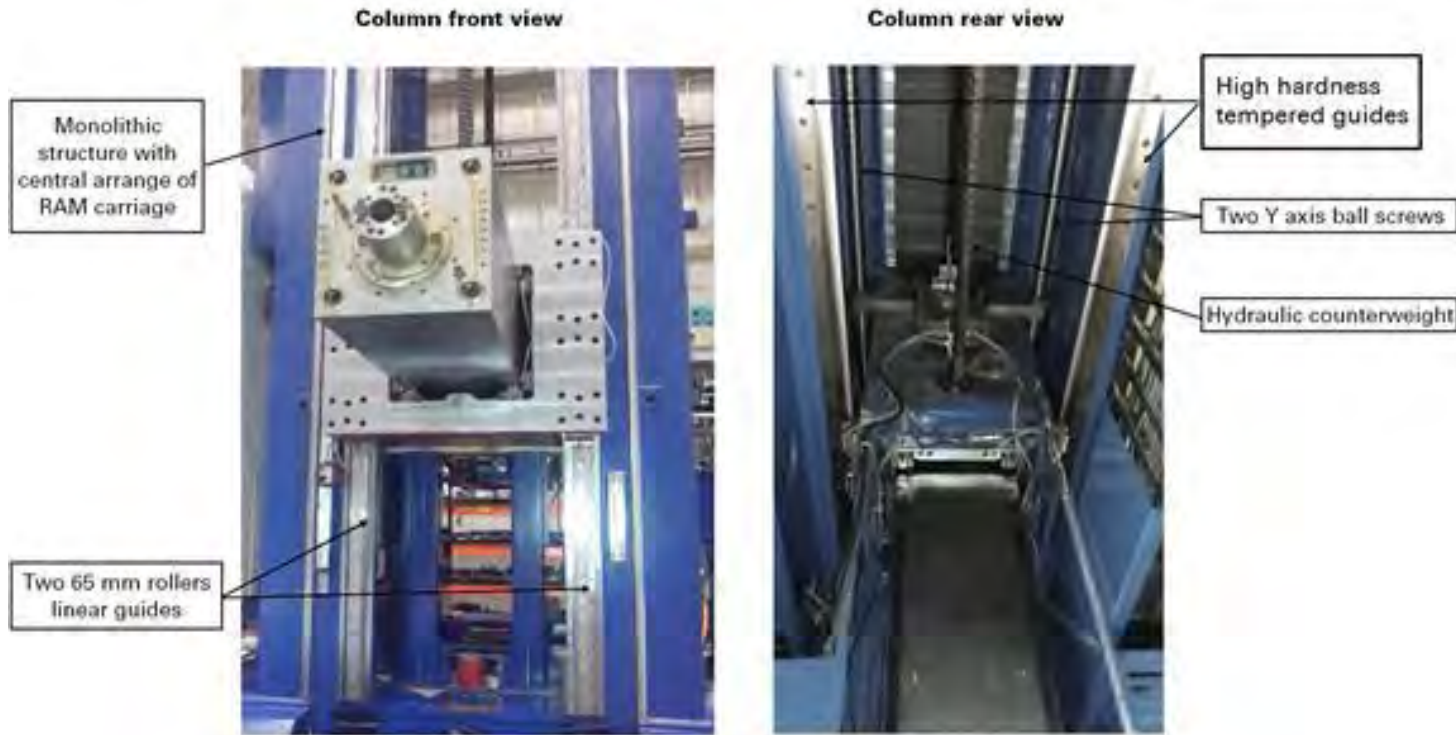

The RAM carriage is fixed using two 65 mm linear roller guides at the front and two VND guides (hardness tempered) at the rear of the column, with 6 front skids and 4 linear rear bearings.

The head is positioned in the center of the double-walled column, in the “Box in Box” concept, having two front and rear guides, providing great geometric stability and high rigidity, responding uniformly to machining forces, regardless of cutting directions .

Technical characteristics



MAUSA

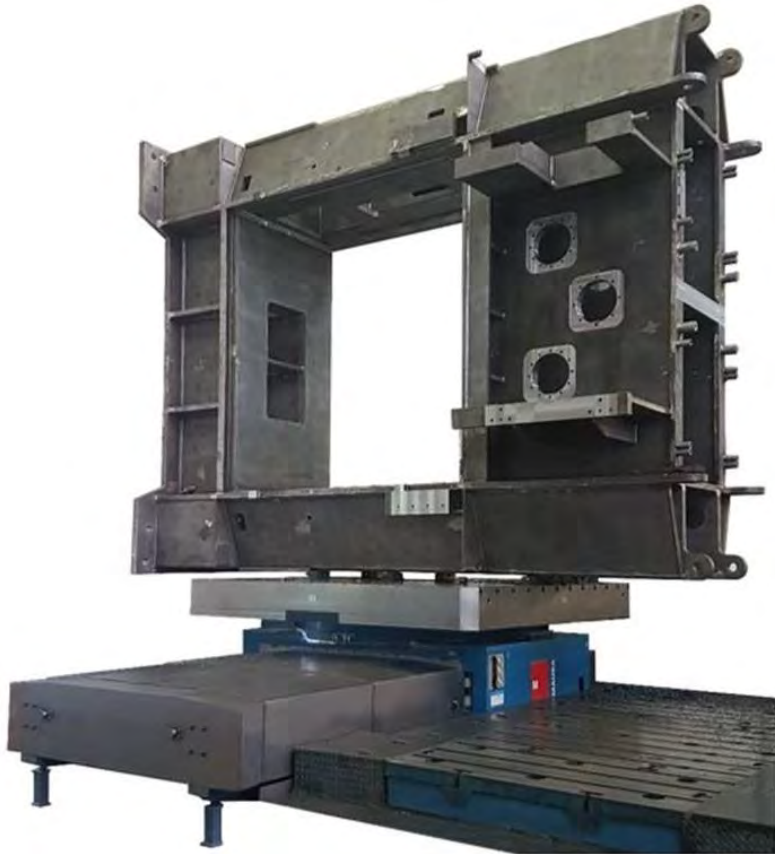

The rotational movement of the table of 66,139 / 132,277 / 220,462 lbs, B axis, on the base, is supported by a hydrostatic system, which consists of a pressurized oil film permanently between the surfaces, eliminating the contact, as well as the consequent wear between the parts.

Transmission is done through two "master / slave" servomotors positioned at 180 degrees and ground helical pinions, transmitting force and torque to a tempered toothed ring fixed to the table.

The linear movement, V axis, is made through a servomotor and recirculating ball screw \varnothing 3.9 in, on four linear roller guides, size 2.6 in.

Technical characteristics



The vertical movement (Y axis) of the RAM car, in the column, is performed by two servomotors, in gantry arrangement and transmitted through two Ø80mm ball screws, positioned symmetrically in the front part of the column.

The mass of the set is balanced through accumulators and hydraulic cylinder, providing smooth and uniform movements, contributing strongly to the quality of finishing machining..

Technical characteristics



The CNC Boring Machine FV 301 is equipped with an Automatic Tool Changer, with a magazine for 60 or 120 positions.



It can be configured with Milling Heads of different models and “pick-up” station for automatic head changing.

Layout example (X = 473" and Y= 197")



MAUSA

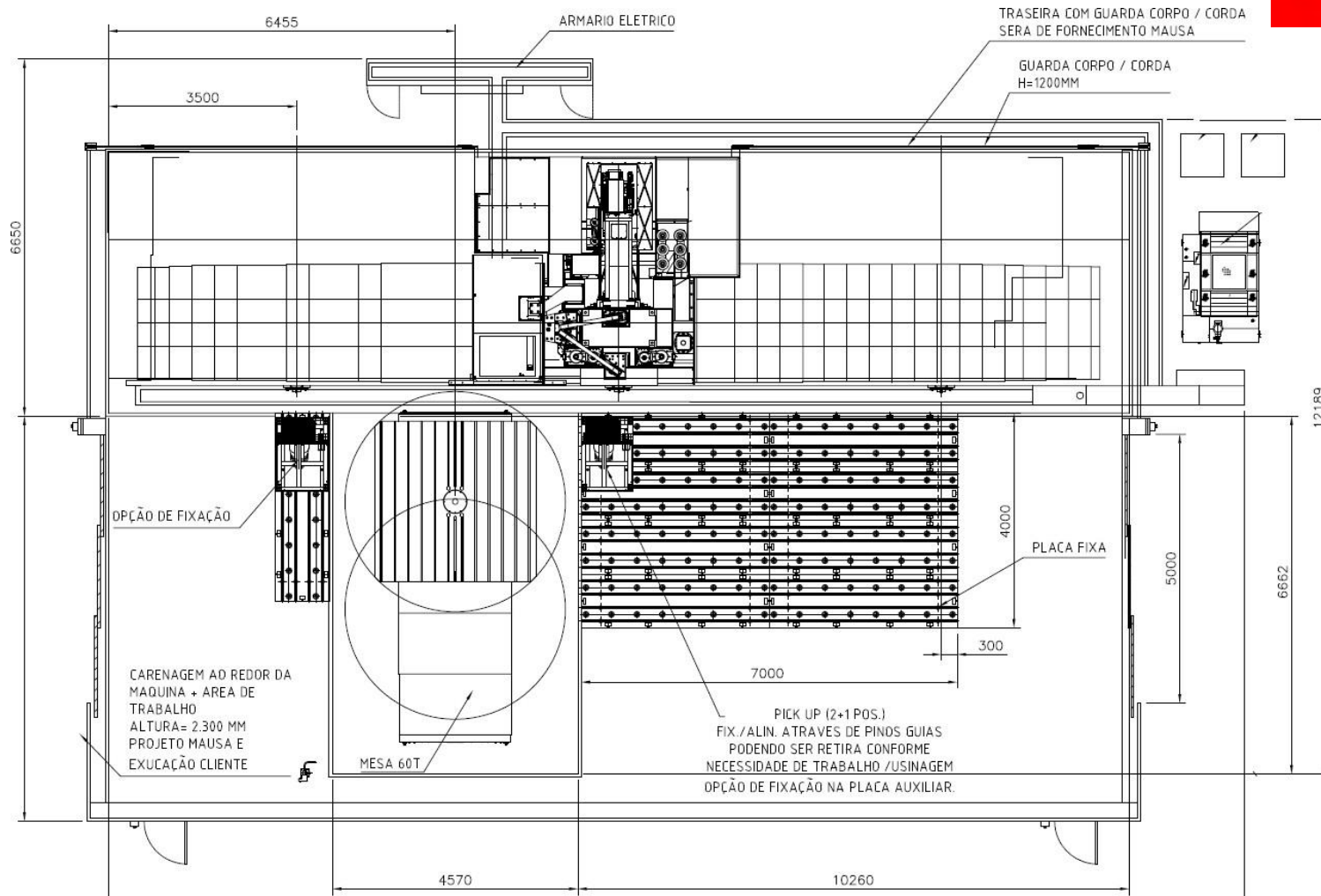

Dimensions in millimeters

Layout example (X = 473" and Y= 197")

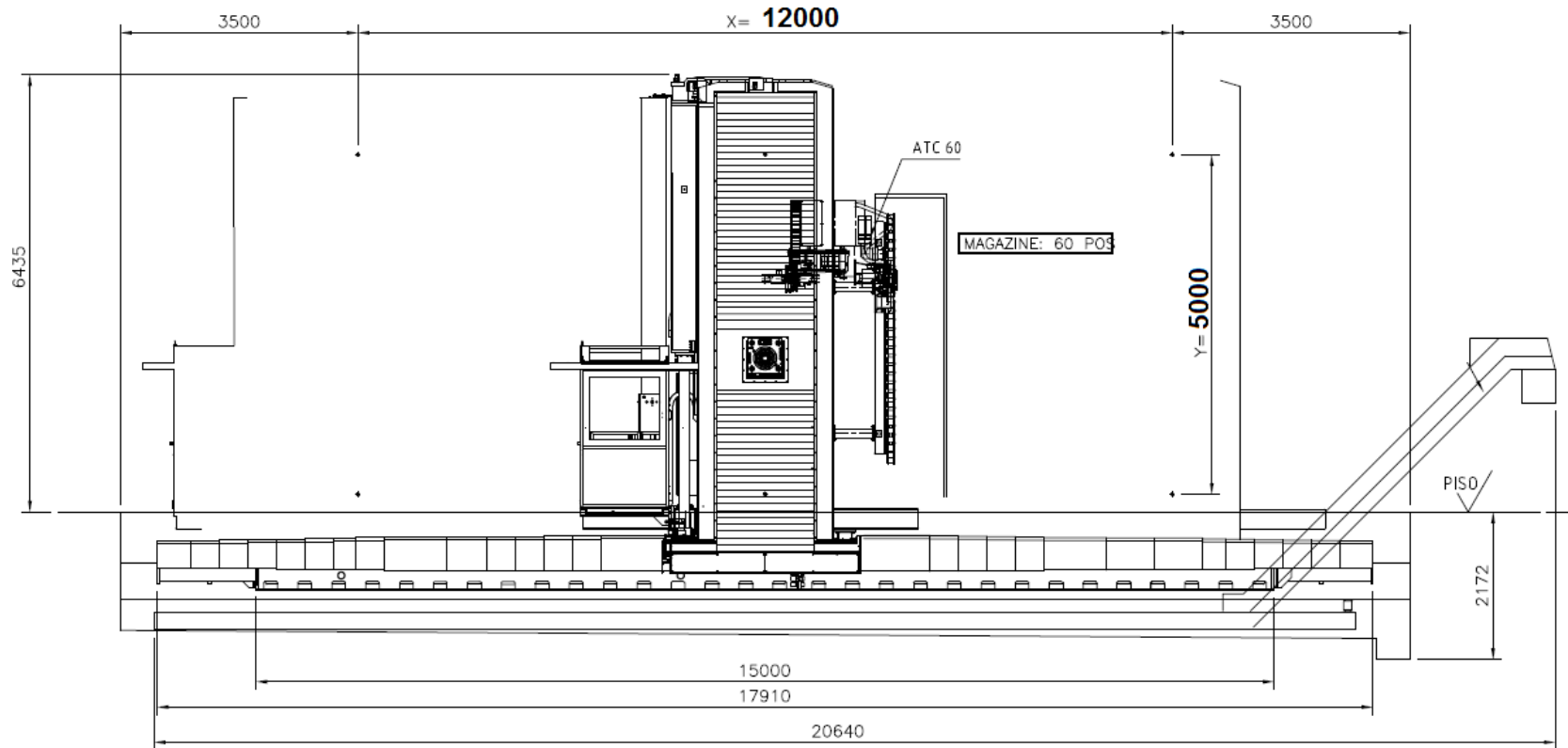

Dimensions in millimeters

Layout example (X = 473" and Y= 197")

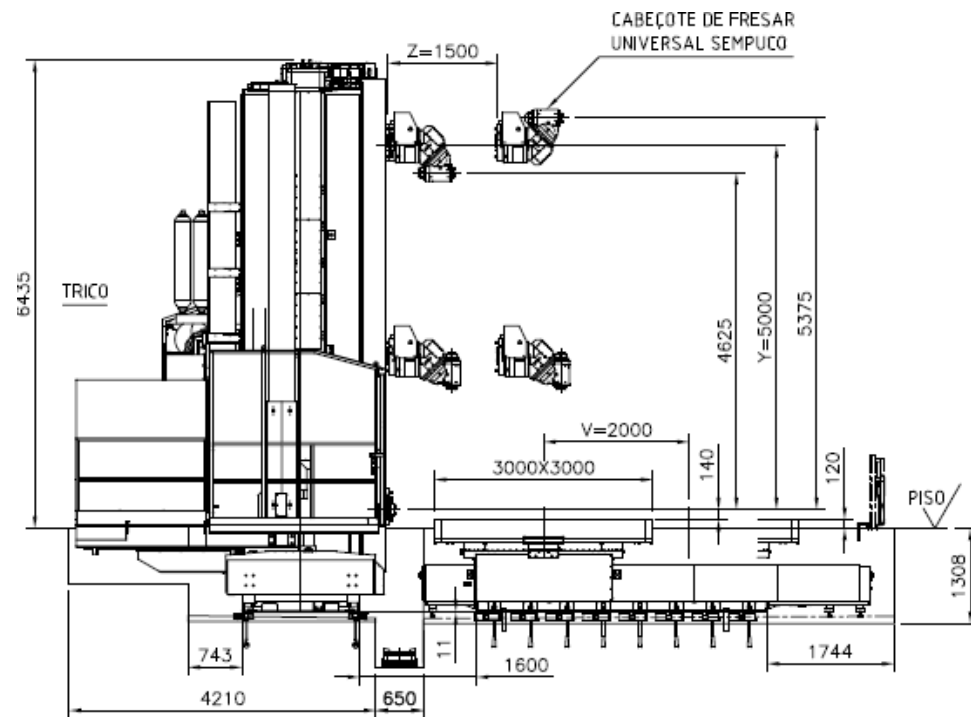
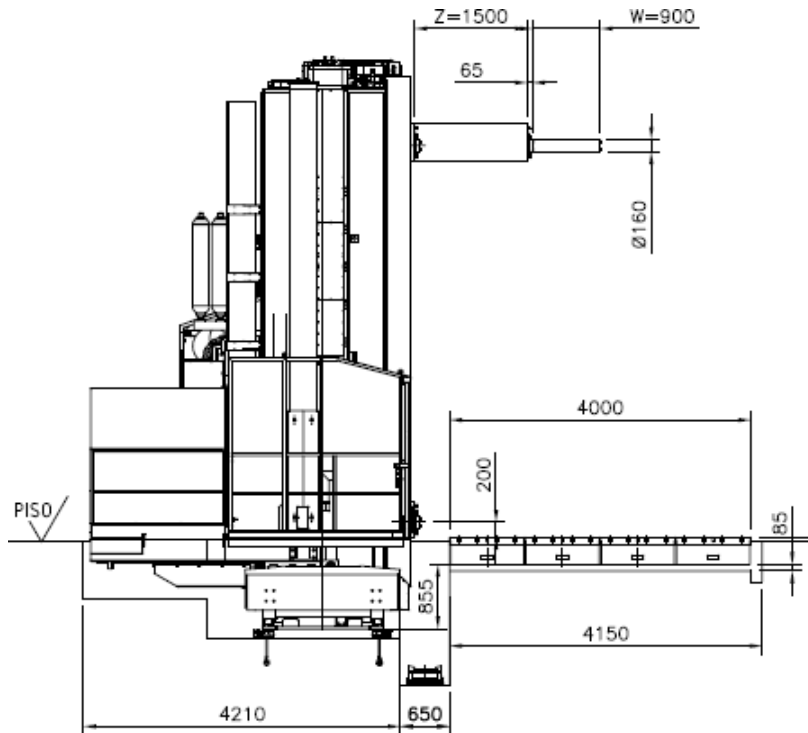

Dimensions in milimeters

FVM 501

“Floor -Type” Boring and Milling Machine

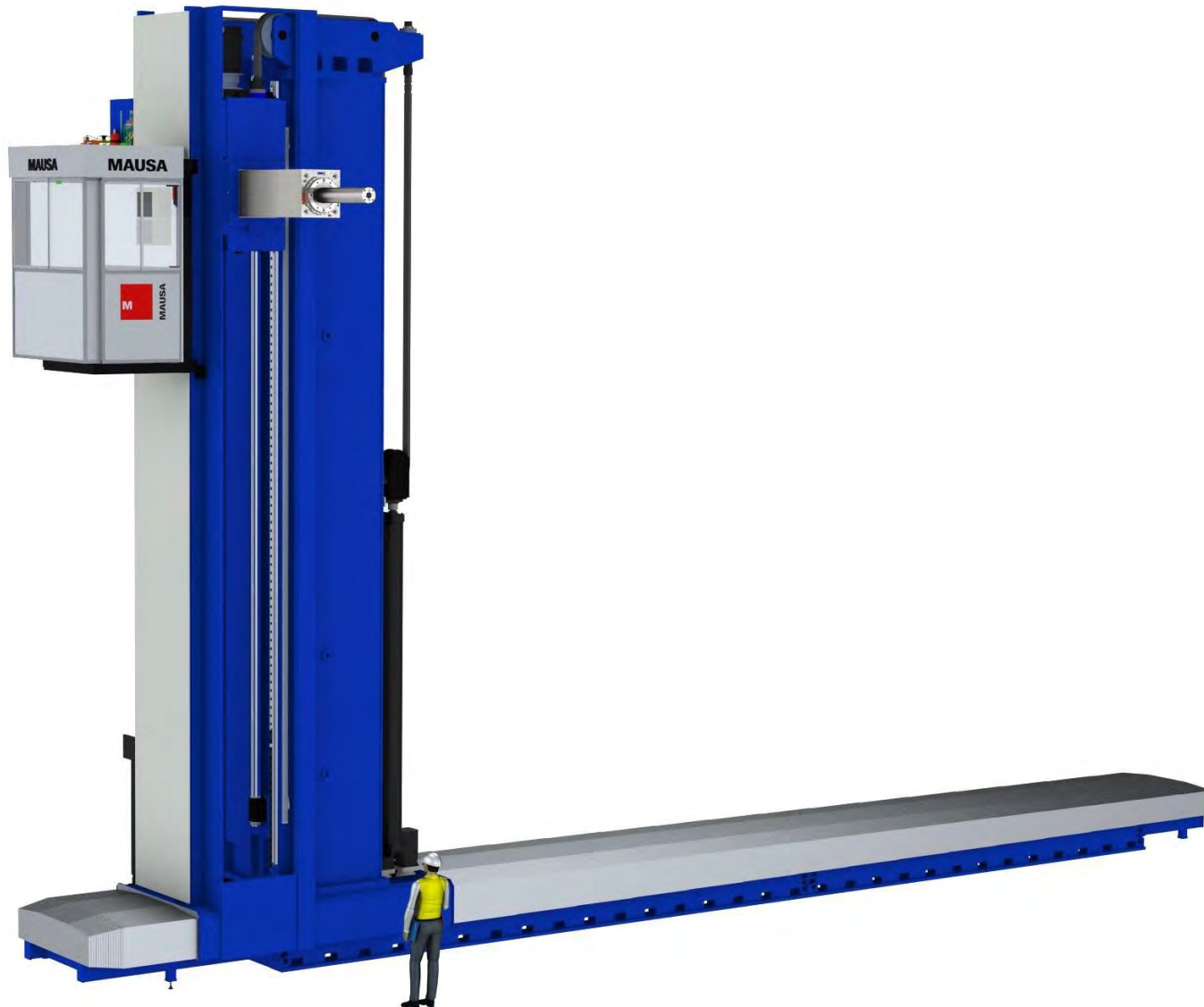

Technical specifications



		FVM 501
Column longitudinal travel (X axis)	in	236.2 + n x 39.4
Headstock vertical travel (Y axis)	in	236.2 / 315
RAM transversel travel (Z axis)	in	59
Boring spindle axial travel (W axis)	in	47.2
Spindle diameter (quill)	in	7.1 or 7.9
Table surface	in	98.4 x 98.4 up to 196.9 x 196.9
Table load capacity	lbs	132,277 / 220,462 / 529,110
Minimum angular increment (B axis)	degrees	0,001°
Linear travel of Table (V axis)	in	78.7 up to 196.9
Spindle Power S1-100% (S6-40%)	HP	135 (161)
Spindle nose	ISO	50
Max speed	rpm	2,200
Speed range (automatic)	unit	3
Nominal torque S1-100%	in lbf	115,680
Rapid traverse X / Z / Y	ipm	787

Technical characteristics



The CNC Boring Machine FV 501 has been designed to meet the segments that need machining of large parts, with high chip removal rates and requirements for a high degree of precision.

On the base (X axis) two 4 inches linear guides of rollers and eight skids are mounted, which guarantee rigidity and uniformity of movement of the column

. The forward force and speed are transmitted by two sets of servomotors and planetary gearboxes, helical rack and double pinions.

The vertical movement (Y axis) of the RAM carriage, in the column, is performed by a high precision servomotor and planetary gearbox and transmitted through a $\varnothing 4.7$ in ball screw. The mass of the set is balanced through accumulators and hydraulic cylinder, providing smooth and uniform movements, contributing strongly to the quality of finishing machining

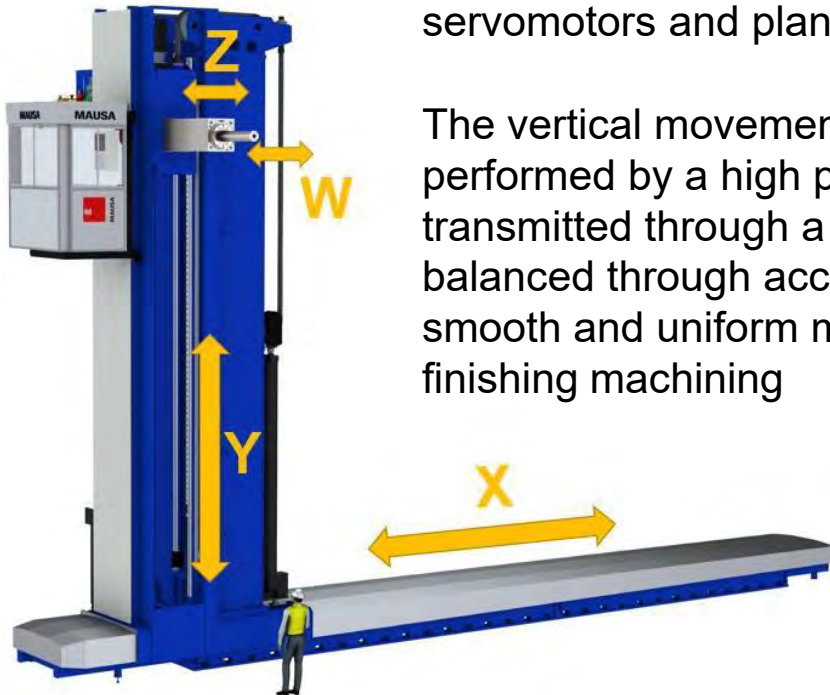

Technical characteristics

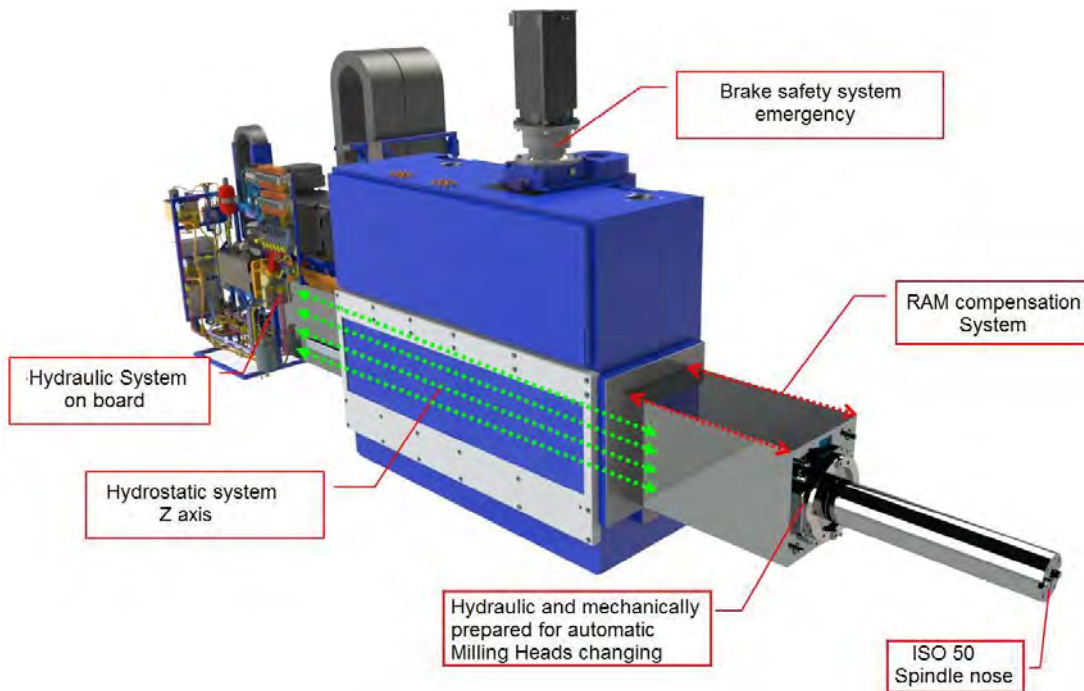

The RAM (Z axis) moves through a hydrostatic bearing formed by a set of 16 bronze shoes with controlled hydraulic pressure, 8 of which are front and 8 rear, thus configuring a single sliding bearing, with very low friction, high rigidity and low susceptibility to vibrations. The movement is driven by a servomotor and recirculating ball screw.

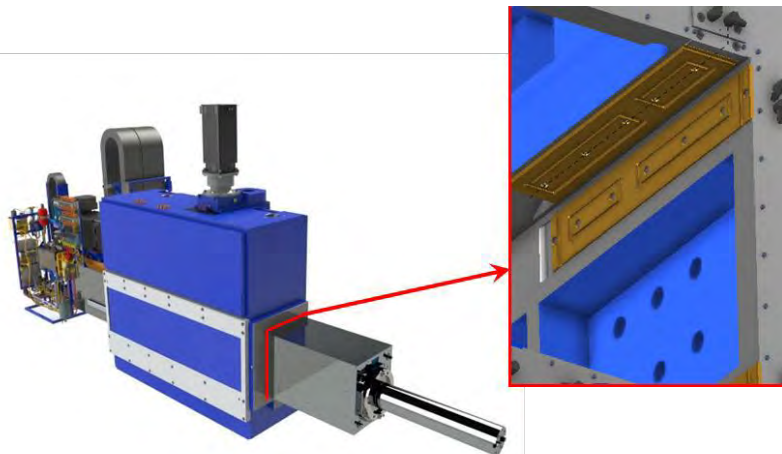

The \varnothing 7.1 or \varnothing 7.9 inches spindle, with ISO 50 is located inside the RAM, is made of forged and nitrided alloy steel. It is assembled with high precision ball bearings. Lubrication is obtained by means of a special system, air-oil, lubricating and cooling the entire set, allowing uninterrupted work at high rpm.

Technical characteristics



- Hydrostatic Rotary Tables up to 120 tons
- Automatic Tool Changer up to 180 positions
- Linha de cabeçotes automáticos CNC posicionadores e contínuos.

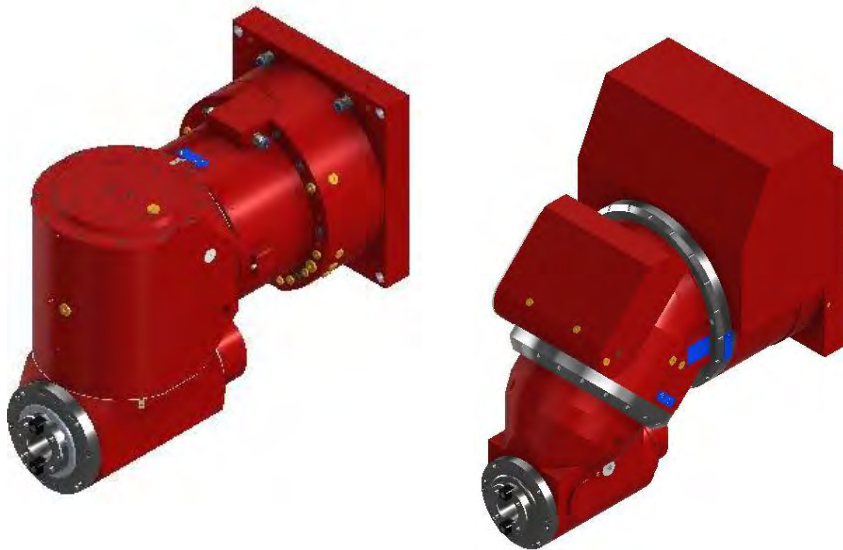

Indexing Milling Heads

Power: 50, 80 or 100 HP

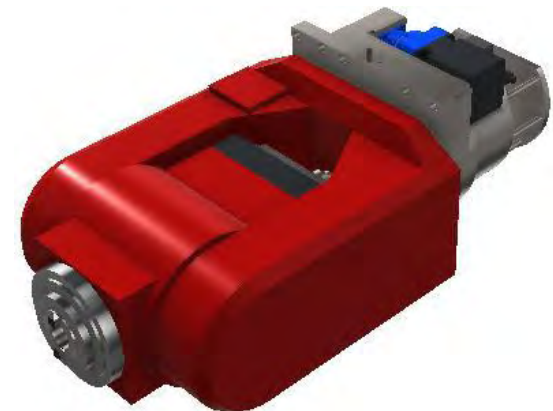

Milling Heads with two continuous axis and spindle motor

Applications



- Oil & Gas;
- Hydraulic turbines “*Hydropower*”;
- Heavy industry;
- Naval industry “*Shipbuilding*”;
- Energy “*Wind Power*”;





MAUSA

az _29/04/2021